

Powervar Series 3200 High Performance Three Phase UPS (10 – 40 kVA)

Selecting, Specifying and Installation Information

Thomas E. Wilson, PE

Wilson Engineered Systems, Inc.
Jacksonville, FL 32258

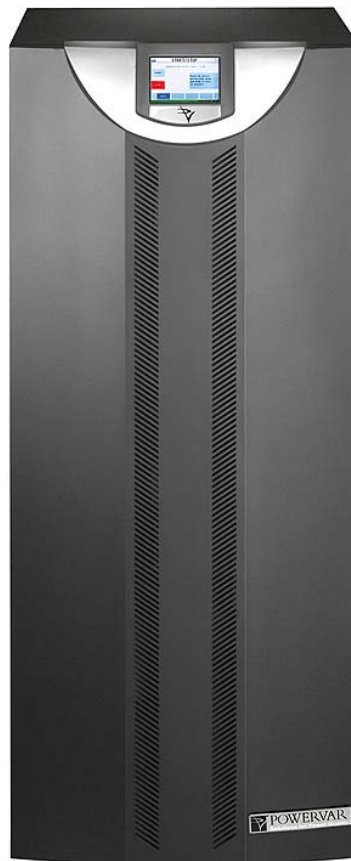

904-880-0118
www.wilsonengineered.com

Powervar Series 3200 Introduction

Powervar was founded in 1986 and is based in Illinois with a single focus on providing clean reliable power on a world-wide basis with over 600 products ranging from ½ amp through 300 kVA. Powervar has been best known in the medical and point of sale application area for power conditioning and backup. They received the 2013 Frost & Sullivan Award for Best Practices referencing global Healthcare and UPS systems. Point of Sale and Healthcare are very demanding power quality environments due to the distributed nature of POS and the inrush demands of healthcare imaging and lab equipment. With the 3200 Series Powervar has brought their demanding standards to the three phase IT market.

The 3200 Series was developed to include performance features which have been value engineered out of many manufacturers current UPS systems including:

- Easy to Understand Color Graphical LCD Display
- Matched IGBT Rectifier/converter and IGBT Inverter
- 0.9 Output Power Factor Rating
- Input Current THD < 2%
- Output THD < 1%
- Wide +/- 15% Input Voltage Acceptability
- 7.5 to 15 kHz Switching Control Allowing High Spec Performance
- 100% Step load Capability w/o Battery Use
- 300% Overload Capability for 10 Seconds
- Generator Compatibility at 1:1 (Generator kW: UPS kVA)
- Automatic Input Current Walk-in Control
- Automatic Restart after Battery Depletion
- Standard Alarm Contacts
- Internal DC Disconnect
- Internal Wrap Around Maintenance Bypass
- REPO Input
- Battery Self Test
- Battery Temperature Monitoring in each Compartment
- Network Connectivity
- Internal and External Battery Options
- Small Footprint
- Factory Test Report Included with Unit
- Two Year Warranty

Powervar Series 3200 Power Topology

Below is a simplified topology of the UPS internal power path. Many UPS in this size are advertised as IGBT transistor based but typically that is only the inverter. The 3200 Series also uses a matched transistorized circuit for the rectifier and thus is a “rabbit – rabbit” matched design, others are a “turtle – rabbit” design and the mismatch exposes the design to significant battery overuse during normal operations. That is because a turtle rectifier cannot keep up with a rabbit inverter, causing the battery to assist when the turtle can’t react fast enough.

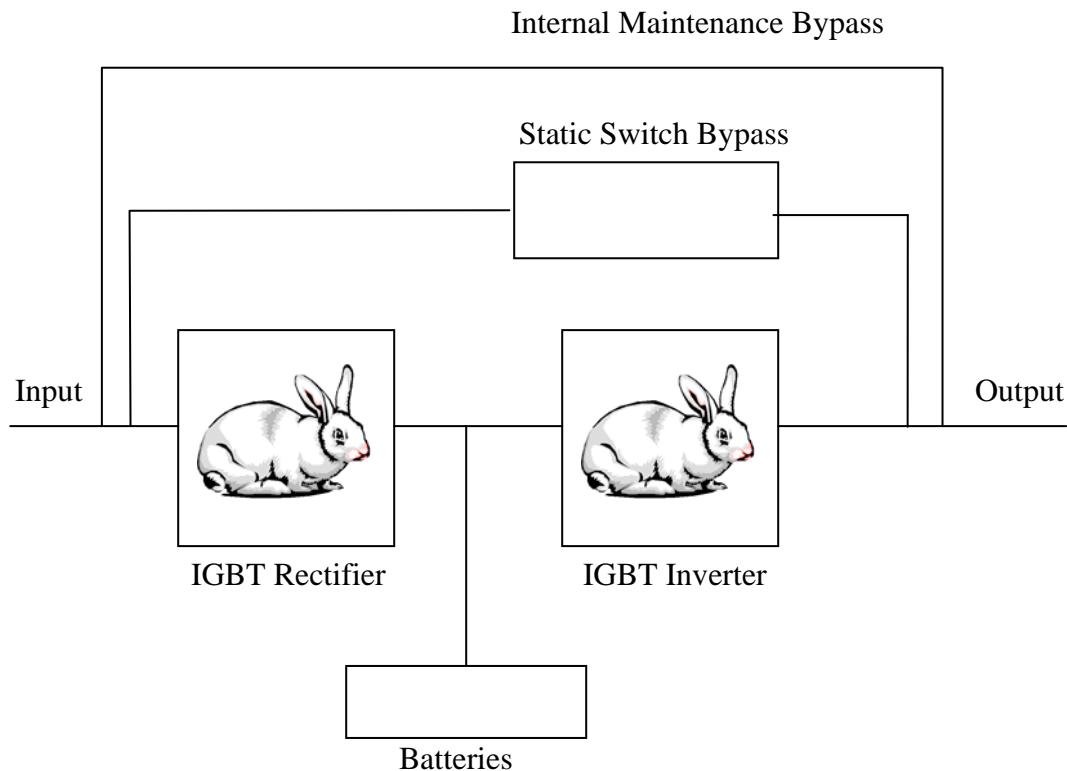

These new UPS modules are lighter, designed for simple single input wiring and are optimized at 120/208 VAC, 3 wire plus ground for additional wiring and installation cost savings. Selection, planning and installation of a UPS system should be easy, yet often it is not. This booklet and the Powervar layout are designed to restore simplicity.

Warranty for the UPS is standard at two years with options for longer. As customers deserve assured reliability Wilson Engineered Systems includes a UPS/Battery PM in each year of the warranty at no charge for local customers.

Benefits

- **High Performance:** The IGBT's used in the rectifier and inverter sections are matched technology that allows fast response to changing loads and high demand harmonic type loads. The benefit is peace of mind that its design can carry virtually any foreseeable load placed on it.
- **Battery Life Extension:** The UPS batteries are charged via the IGBTs in the rectifier with their high frequency control. This provides for cleaner DC Charging voltage when compared to diode bridge and SCR rectifiers which in essence allow the batteries to see utility variations directly. Those DC bus variations are ripple that the batteries must endure. Ripple raises battery internal temperatures and reduces battery life. The Powervar configuration is soft on batteries and this UPS continues the concept. Additionally a battery test control circuit routinely tests the battery string(s) for failure. The benefit is extended battery life and less frequent battery replacements.
- **Generator Friendly:** Most UPS manufacturers use 6 or 12 pulse SCR rectifiers to convert AC power to DC on the front end of the UPS. That is a highly distorted 1970's methodology. To reduce the distortion, they incorporate capacitor based filters which need high cost capacitor change out every 5 years. The filters do make these types of UPS friendlier to generators when heavily loaded. However, at light load the capacitors create problems for generators and UPS manufacturers have to add more components to switch the capacitors out of the circuit at lighter UPS loads. All very complicated and the generator still sees high distortion at light loads. The IGBT rectifier is state of the art and provides for clean, sinusoidal current draw without needing capacitors. This is done by high frequency transistor control permitting the UPS to control its current draw very finely at all load points. The UPS requires only 1 kW of generator for each kVA of UPS power. Traditional UPS designs with 6 and 12 pulse rectifiers can require the generator to be sized as high as 2.5 kW per kVA of UPS! The benefit is more reliable generator operation and dollars savings due to smaller generators.
- **Space and Weight Savings:** The 3200 Series UPS has been designed physically smaller and lighter than past UPS. Space and weight savings are always a benefit.
- **Reduced Air Conditioning:** The 3200 Series technology will reduce the air conditioning need. The benefit is upfront savings on air conditioning first cost followed by years of savings in operating cost.
- **Low Cost Operation:** The UPS operates at lower operating cost than many other UPS. The bottom line cost of IT operations being reduced allows precious IT or facilities operating budget dollars to be spent or saved for better corporate benefit.

Warranty/Service

The 3200 Series UPS comes with a two year warranty. In short, the warranty covers parts, labor and travel for 24 months from shipment of the UPS. This covers the UPS and battery for defects.

Preventative Maintenance Programs are available during the warranty and post warranty. These are listed in the Preventative Maintenance Programs portion of this document. Wilson Engineered Systems is a fully trained Authorized Service Provider (ASP) for multiple UPS manufacturers. Wilson Engineered Systems was awarded the top ASP in the Southeast United States for Toshiba in the fiscal 2009/2010 year. As there are approximately 100 service locations in the US this is a high honor to be singled out for the award and it verifies the priority Wilson Engineered Systems places on customer support.

Dimensions

10 kVA/ 9 kW and 20 kVA/ 18 kW UPS

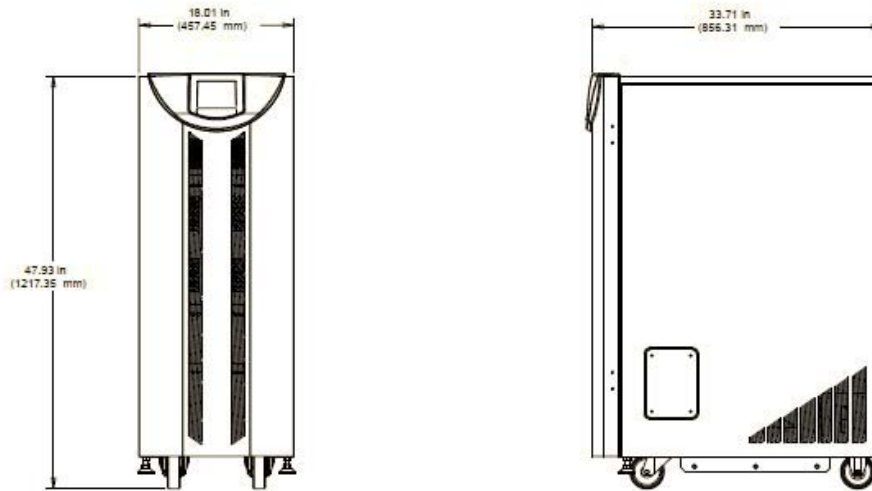

Cable Entry: Bottom Preferred, Side Available
Connections: Recommend flex to allow UPS to roll forward 36"
Dimensions/Weight: 18" w x 34" d x 48" h, 10 kVA - 600 lbs., 20 kVA - 700 lbs.
Color: Black
Clearances: 36" Front, 12" Rear, 6" Left and Right Side
Typical Lead Time: Stock

Available Options

Add-On Battery Cabinets: 18" w x 34" d x 48" h, weight varies with run time (from 550 to 1,900 lbs, each)
Matching External Bypass: 24" w x 34" d x 48" h
Wall Mount External Bypass: 24" w x 9" d x 38" h
480 V Transformer Cabinet: 30" w x 34" d x 48" h. 500 lbs

UPS Modules

30 kVA/ 27 kW and 40 kVA/ 32 kW UPS (28.8 also*)

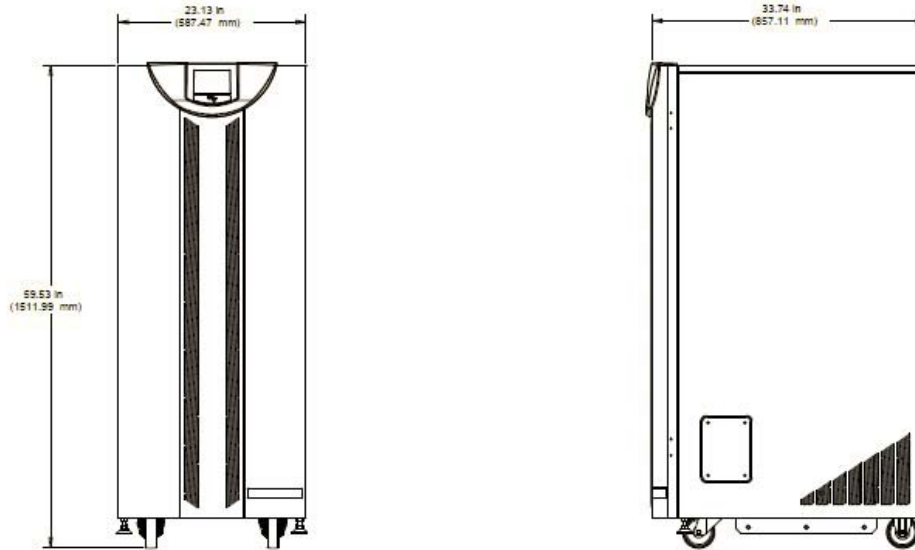

Cable Entry: Bottom Preferred, Side Available
Connections: Recommend flex to allow UPS to roll forward 36"
Dimensions/Weight: 23.2" w x 33.71" d x 47.93" h, 30 & 40 kVA - 1,050 lbs.
Color: Black
Clearances: 36" Front, 12" Rear, 6" Left and Right Side
Typical Lead Time: Stock

Available Options

Add-On Battery Cabinets: 29" w x 34" d x 60" h, weight varies with run time (from 875 to 2,500 lbs, each)
Matching External Bypass: 3" w x 34" d x 48" h
Wall Mount External Bypass: 30" w x 12" d x 43" h
480 V Transformer Cabinet: 30" w x 34" d x 60" h. 650 lbs

*Note: 28.8 kVA offering is a derated 30 kVA to use on 100A circuit feeds as many feed panels allow only up to a 100A breaker to fit. The 28.8 kVA rating allows the maximum power from a 100A breaker per code.

Typical System Configuration - One Line Drawings

Below is standard configuration #1. This is the simplest, lowest cost configuration. This configuration and relies upon the internal maintenance bypass for service.

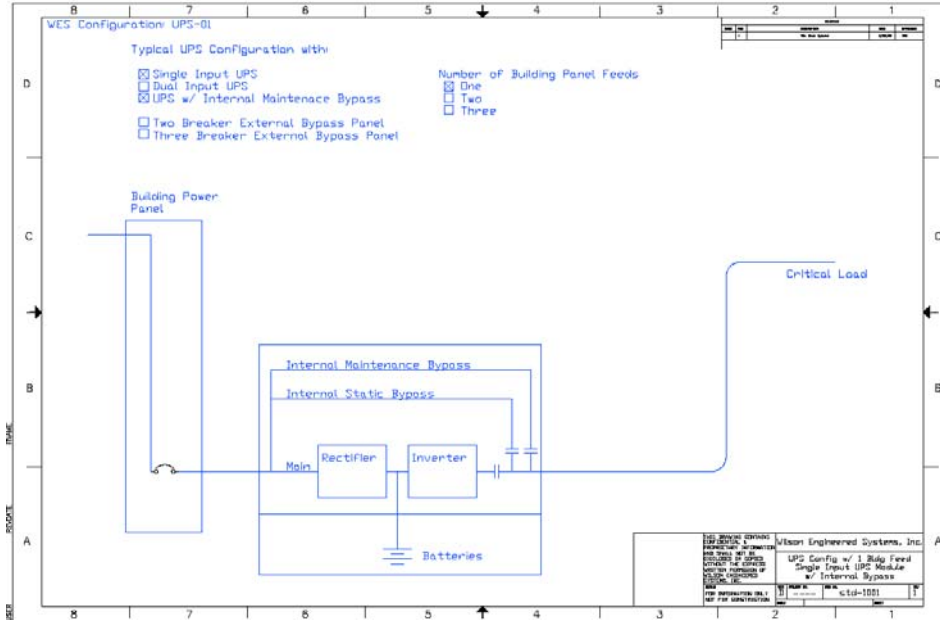

Configuration #2 below adds an external maintenance bypass circuit which assures service or testing may be performed without effect upon the load. It is the safest and recommended installation configuration.

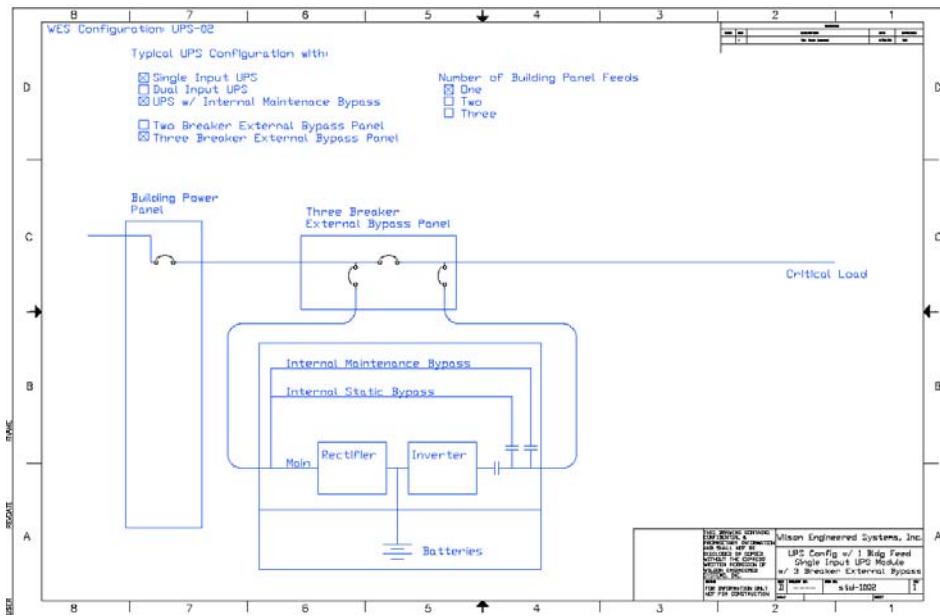

Installation Planning

Based upon 208 volt application the following apply.

kVA	kW	Nominal Input Amps	Input Breaker	Output Amps	Min Output Breaker	Max Battery Current	Approx. Heat Output
10	9	28.4	40	28	35	27.1	3.8 kBTU/Hr
20	18	56.7	80	55.5	70	54.2	7.6 kBTU/Hr
28.8	23	70.9	100	79.9	100	69.3	7.8 kBTU/Hr
30	27	83.2	125	83.3	110	81.4	9.1 kBTU/Hr
40	36	110.9	150	112	150	108.5	12.2 kBTU/Hr

Wall Mount Maintenance Bypass Section

We recommend all UPS systems be installed with a true maintenance bypass circuit. An external maintenance bypass circuit allows any type of service or replacement to be performed on the UPS system without requiring a critical load shutdown. It is not an expensive option and is extremely valuable when needed..

Module Size (kVA)	Input Breaker	Bypass & Output Breaker	Dimensions W x D x H (inches)
10	40 A	35 A	24 x 9 x 38
20	80 A	70 A	24 x 9 x 38
28.8	100 A	100 A	24 x 9 x 38.7
30	125 A	110 A	30 x 12 x 42
40	150 A	150 A	30 x 12 x 42

Battery Cabinet Options

There is a wide range of battery options available for the UPS. The most common selection is VRLA batteries in cabinets. Additional battery predictive health monitoring is available where each battery is individually monitored for both voltage and impedance. Each battery cabinet contains a battery circuit breaker to allow isolating the battery cabinet for service.

Battery Reserve Time is generally recommended to be 5 minutes minimum even when a generator is involved. This is to ensure battery support as the batteries age and minimize high DC current for a given application. Maximum battery time is only limited by physical constraints of size, weight and wiring capability.

In initially selecting a battery consider the following.

1. Batteries are the weakest point in a UPS system. N+1 Redundancy of battery cabinets should be considered for high reliability needs. Automated individual battery health monitoring, described later within this document, will enhance system reliability. Use of the charts simplifies knowing how much battery time will remain if one battery cabinet is out for service or failure.
2. When designing for N+1 battery cabinet reliability, be sure that desire is known and considered in the battery breaker sizing as standard manufacturer policies typically do not plan for related battery cabinet breaker redundancy. This adds minor cost but must be engineered upfront.

Battery Health Monitoring

Wilson Engineered Systems has long been involved in battery health monitoring (since 1993) and the BTECH Impedance/Voltage/Temperature based battery health monitor is an available option with the UPS.

BTECH manufactures the only patented online real-time impedance monitor which minimizes the chance of batteries being compromised at the most critical moment. The system is comprised of two principle components: the Battery Validation System (BVS) hardware and Battery Validation Manager (BVM) software. The system provides:

- Individual unit/cell impedance monitor
- Pilot unit/cell temperature monitor
- Individual unit/cell voltage monitor
- Total voltage monitor
- String current float and discharge monitor
- Battery discharge monitor
- Cycle counter monitor
- Real-time system monitoring

A rise in a battery's impedance signifies diminished battery health. The picture below on the left shows this. The BVM Software trends impedance readings and automatically alerts users. During outages the system tracks individual battery performance as shown on the picture below on the right. The BTECH system continually informs with preemptive data, allowing proactive battery preventative maintenance before disaster can strike.

Each system is engineered for the specific battery and UPS application. Users with multiple UPS can run a common software copy to monitor multiple battery systems globally.

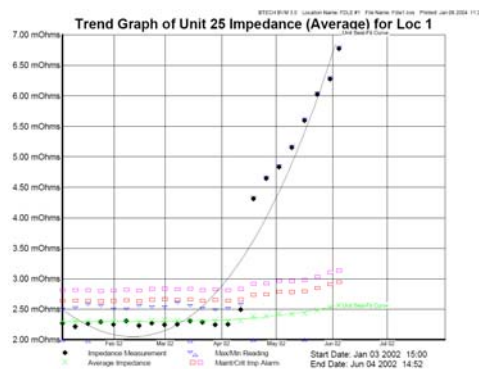

Impedance rise = failing battery

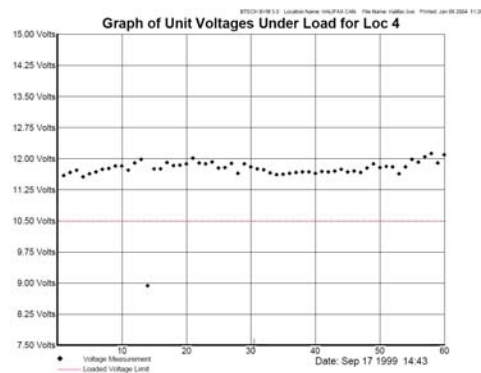

Voltage drop under load = weak battery

Preventative Maintenance Programs

Preventative Maintenance Programs are available. Being a high quality, highly reliable UPS does not eliminate benefits of maintenance. With a multi-year warranty some may think to delay service until the warranty has expired. However, warranty is for coverage of factory defects. If misuse, lack of maintenance, environment or other field condition initiates an issue it is very possible warranty would not cover needed service. Proper preventative maintenance is the best assurance of long term reliable operation.

We all want to think our facilities are always clean and equipment stays in top notch condition but here are bits of reality. These are real photos of UPS we've been called in to service. Unfortunately, we have seen these issues at multiple sites.



Dusty Control Board



Dust Covered Heat Sink



Corrosion on Battery Cable

UPS are not able to work and provide full design capabilities when conditions like these shown above exist. Dust buildup can create an electrical bridge (short circuit) between control board components, dust covered heat sinks will allow components to overheat. Battery cable corrosion increases DC system impedance and lowers charging capability and discharge performance. All these are easily prevented when equipment is properly and routinely maintained.

Standard service includes:

- **Preventative Maintenance Visit Plans** for single visits to inspect, service, clean and calibrate the UPS and batteries.

- **Annual Preventative Maintenance Plans**
 - Level I – Basic Plan
 - Two PMs per year
 - (1st) UPS and Batteries
 - (2nd) Batteries
 - Level II – Recommended Plan
 - Four PMs per year
 - (2) UPS and Batteries
 - (2) Batteries
 - Level II – Custom Plan
 - Configured as desired by customer

- **Battery Replacement Services**

Visit the Warranty Section of this document for explanation of the warranty and extended warranty options available.

Wilson Engineered Systems is a fully trained Authorized Service Provider (ASP) for multiple UPS manufacturers. We are proud of this achievement. Wilson Engineered Systems was awarded top ASP in the Southeast United States for Toshiba 2009. As there are approximately 100 service locations in the US this is a high honor to be singled out for the award and it verifies the priority Wilson Engineered Systems places on customer support.

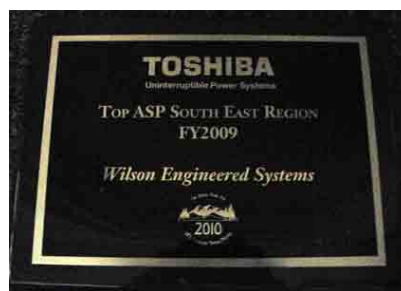

Who We Are



Wilson Engineered Systems is a hybrid IT Infrastructure supply company. Our company is based in Jacksonville, FL and was founded in 1992. Our IT experience dates back to 1981. We design, supply and service the infrastructure supporting IT equipment. As a registered professional engineer based company, we provide sound equipment and design with equipment optimized for this environment. Goal #1 is reliability, followed by economical life cycle costs, usability and serviceability. Our main area of concentration is UPS and overall power delivery systems. We also provide technical furniture, server cabinets, critical monitoring and air conditioning. We offer system design engineering services for all areas and have done so for sites ranging from small server rooms to large 2 mega watt industrial plants. Realizing proper maintenance of critical equipment is paramount to reliability, we also provide full service for equipment we supply.