

G9000 SERIES

INSTALLATION AND OPERATION MANUAL

480/480 V 100/160/225/300/500/650/750 kVA



Document: 61480-013
Ref: 4GBA0012 Rev. E
March 2015



G9000 SERIES

INSTALLATION AND OPERATION MANUAL

480/480 V 100/160/225/300/500/650/750 kVA

Document No. 4GBA0013 Rev. E
P/N 61480-013
March 2015



IMPORTANT NOTICE

The Instructions contained in this manual are not intended to cover all of the details or variations in equipment or to provide for every possible contingency to be met in connection with installation, operation, or maintenance. Should further information be required or should particular problems arise which are not covered sufficiently the matter should be referred to the local TOSHIBA sales office.

The contents of this instruction manual shall not become a part of or modify any prior or existing equipment, commitment, or relationship. The sales contract contains the entire obligation of TOSHIBA INTERNATIONAL CORPORATION. The warranty contained in the contract between the parties is the sole warranty of TOSHIBA, and any statements contained herein do not create new warranties or modify the existing warranty.

Any Electrical or mechanical modifications to this equipment without prior written consent of TOSHIBA will void all warranties and may void UL/CUL listing. Unauthorized modifications may also result in equipment damage, personal injury, or loss of life.

UNINTERRUPTIBLE POWER SYSTEM

If additional information or technical assistance is required call TOSHIBA Customer Support Center toll free at 1- 800-231-1412, or write to: Toshiba International Corporation, 13131 West Little York Road, Houston, TX 77041-9990 Attn: UPS Product Manager.

Please complete the following information for your records. Unless otherwise specified on the warranty card, the warranty period for the UPS or UPS part is 36 months from the shipment date (see bill of lading).

Unless otherwise specified on the warranty card, the warranty period for a UPS battery is 36 months full replacement, and an additional 7 years pro-rated from the shipment date (see bill of lading).

Keep this manual with the UPS equipment.

Job Number: _____

Model Number: _____

Serial Number: _____

Application: _____

Shipping Date: _____

Date of Installation: _____

Inspected By: _____

Purpose and Scope of Manual

This manual provides information on how to safely install, operate, and maintain your TOSHIBA power electronics product. This manual includes a section on General Safety Instructions that describes the warning labels and symbols that are used throughout the manual. Read the manual completely before installing, operating, or performing maintenance on this equipment.

This manual and the accompanying drawings should be considered a permanent part of the equipment and should be readily available for reference and review. Dimensions shown in the manual are in metric and/or the English equivalent.

TOSHIBA reserves the right, without prior notice, to update information, make product changes, or to discontinue any product or service identified in this publication.

TOSHIBA is a registered trademark of TOSHIBA INTERNATIONAL CORPORATION. All other product or trade references appearing in this manual are registered trademarks of their respective owners.

TOSHIBA shall not be liable for technical or editorial omissions or mistakes in this manual. Nor shall it be liable for incidental or consequential damages resulting from the use of information contained in this manual.

This manual is copyrighted. No part of this manual may be photocopied or reproduced in any form without the prior written consent of TOSHIBA INTERNATIONAL CORPORATION.

© Copyright 2014 TOSHIBA INTERNATIONAL CORPORATION.

All rights reserved.

Printed in Japan

Contacting TOSHIBA Customer Support Center

The TOSHIBA Customer Support Center can be contacted to obtain help in resolving any **Uninterruptible Power System** problem that you may experience or to provide application information.

The center is open from 8 a.m. to 5 p.m. (CST), Monday through Friday. The Support Center's toll free number in USA is (855) 803-7087.

You may contact TOSHIBA by writing to:

TOSHIBA INTERNATIONAL CORPORATION.
SOCIAL INFRASTRUCTURE SYSTEMS GROUP
POWER ELECTRONICS DIVISION
13131 West Little York Rd.
Houston, TX 77041-9990
Attn: UPS Product Manager

www.toshiba.com/tic/industrial/uninterruptible-power-systems

±

This page left intentionally blank

Table of Contents

List of Tables.....	ii
List of Figures.....	iii
1 How to use this Manual.....	1
2 INTRODUCTION	2
2.1 SAFETY PRECAUTIONS	3
3 GENERAL.....	6
3.1 DEFINITIONS.....	7
3.2 OPERATION OVERVIEW.....	8
3.2.1 Normal operation: Load power supplied by each system UPS inverter.....	8
3.2.2 Bypass Operation: Load Power supplied through UPS internal static bypass line.....	9
3.2.3 Battery Operation: Load Power supplied by UPS battery.....	10
3.2.4 UPS Parts Location.....	11
3.2.5 PCB Layouts.....	15
3.3 SPECIFICATIONS	19
4 OPERATOR CONTROLS AND INDICATORS.....	26
4.1 LED DISPLAY	26
4.2 EPO BUTTON (Emergency Power Off button) (7).....	27
4.3 LIQUID CRYSTAL DISPLAY (8).....	27
4.3.1 Test Mode Options	27
4.3.2 Menu	28
4.3.3 Input Power Failure	32
4.3.4 Fault Indication.....	32
4.4 EXTERNAL AUX CONTACT INPUT AND OUTPUT TERMINAL BLOCKS.....	34
4.4.1 Aux contacts - Input	34
4.4.2 Aux Contacts - Output.....	37
5 INSTALLATION AND OPERATION	40
5.1 TRANSPORTATION AND INSTALLATION.....	40
5.2 INSTALLATION PROCEDURE.....	40
5.3 PROCEDURE FOR CABLE CONNECTIONS	41
5.4 OPERATING PROCEDURES.....	65
6 RESPONSE TO UPS FAILURE	69
7 PARTS REPLACEMENT	70
8 FAULT CODES.....	71
9 DAILY INSPECTION.....	78
APPENDIX A – Installation Planning Guides (IPG)	79

List of Tables

Table 2-1	UPS Installation Environment.....	4
Table 2-2	Rating of Bypass Input Circuit Breaker.....	5
Table 3-1	Circuit Breaker/Contactor Function	15
Table 3-2	DPAU-81 Switch/Button Function.....	15
Table 3-3	Power Specifications	19
Table 3-4	UPS Module Information.....	20
Table 3-5	Detail of Specifications	21
Table 3-6	Typical UPS Efficiencies at Various Loads.....	24
Table 3-7	MTBF and MTTR	24
Table 3-8	Rating of Contactors, Breakers and Fuses.....	25
Table 4-1	External Input Functions	36
Table 4-2	External Output Functions	38
Table 5-1	Transport by Overhead Crane	40
Table 5-2	List of UPS Weights.....	40
Table 5-3	Maximum Recommended Fault Current.....	41
Table 5-4	Recommended Cable Sizes	44
Table 5-5	Crimp Type Compression Lug.....	45
Table 7-1	Standard Replacement Parts List.....	70
Table 7-2	Air Filters.....	71
Table 8-1	Fault Code	72
Table 9-1	How to Perform Daily Inspection	78

List of Figures

Figure 3-1	Single Line Diagram – Normal Operation: Load powered by UPS inverter	8
Figure 3-2	Single Line Diagram – Bypass Operation: Load fed through static bypass line.	9
Figure 3-3	Single Line Diagram – Battery Operation.....	10
Figure 3-4	UPS Parts Location (100kVA).....	11
Figure 3-5	UPS Parts Location (160, 225kVA).....	11
Figure 3-6	UPS Parts Location (300kVA).....	12
Figure 3-7	UPS Parts Location (500kVA).....	13
Figure 3-8	UPS Parts Location (650kVA & 750kVA).....	14
Figure 3-9	Display PCB DPAU-81	15
Figure 3-10	External I/F PCB IOAU-09.....	16
Figure 3-11	Parallel I/F PCB IFAU-08 (100-225kVA)	16
Figure 3-12	Parallel I/F PCB IFAU-09 (300-750kVA)	16
Figure 3-13	MAIN PCB UPGR-M	17
Figure 4-1	Operation/Display Panel (Front panel).....	26
Figure 4-2	Main Screen	28
Figure 4-3	Startup/Shutdown Guidance	29
Figure 4-4	Startup Guidance	29
Figure 4-5	Shutdown Guidance	29
Figure 4-6	Input values	30
Figure 4-7	Battery Operation Values	30
Figure 4-8	Output values	30
Figure 4-9	Remote/Local operation select.....	31
Figure 4-10	Date & Time adjustment.....	31
Figure 4-11	Log menu.....	31
Figure 4-12	Event Log	32
Figure 4-13	Battery log	32
Figure 4-14	Main Screen (Battery Operation).....	32
Figure 4-15	Measurement screen (Battery Operation).....	32
Figure 4-16	Main screen (Fault indication)	33
Figure 4-17	Message Screen	34
Figure 4-18	Control Wiring for Aux Input Contacts.....	35
Figure 4-19	External Signal Input Terminal Block (with default settings)	35
Figure 4-20	Control Wiring for Aux Output Contacts	37
Figure 4-21	External Signal Output Terminal Block (with default settings)	38
Figure 5-1	UPS Terminal Designation	45
Figure 5-2	Diagram of input/output bus bars and terminal blocks (100-225kVA).....	46
Figure 5-3	Diagram of input/output bus bars and terminal blocks (300kVA).....	47
Figure 5-4	Diagram of input/output bus bars and terminal blocks (500kVA).....	48
Figure 5-5	Diagram of input/output bus bars and terminal blocks (650kVA & 750kVA).....	49
Figure 5-6	Detail of the main cabinet bus bars (300kVA).....	50
Figure 5-7	Detail of the main cabinet bus bars (500kVA).....	51

Figure 5-8	Detail of the main cabinet bus bars (650kVA & 750kVA).....	52
Figure 5-9	Bus bar connection between main cabinet and landing cabinet (300kVA).....	53
Figure 5-10	Bus bar connection between main cabinet and landing cabinet (500kVA).....	54
Figure 5-11	Bus bar connection between main cabinet and landing cabinet (650kVA & 750kVA).....	55
Figure 5-12	Diagram of Power Wire & Control Wire Inter-Connect between UPS and Battery.....	56
Figure 5-13	Diagram of Power Wire Connections (Parallel System Configuration).....	57
Figure 5-14	Diagram of Comm., Power, & Control Wire Connections for 4 units in MMS Config . (100-225kVA)	58
Figure 5-15	Diagram of Communication, Power & Control Wire Connections for 2 units in MMS Configuration (300-750kVA).....	59
Figure 5-16	Detail of IFAU-09 Control Wire Connections for 2 units in MMS Configuration (300-750kVA)	60
Figure 5-17	Diagram of Power Wire & Control Wire Connections for 3-4 units in MMS Config. (300-750kVA)	61
Figure 5-18	Detail of IFAU-09 Control Wire Connections for 3 or 4 units in MMS Configuration.....	62
Figure 5-19	Diagram of Power Wire & Control Wire Connections for 5 to 8 units in MMS Configuration (300-750kVA)	63
Figure 5-20	Detail of IFAU-09 Control Wire Connections for 5 to 8 units in MMS Configuration (300-750kVA)	64
Figure 5-21	Circuit Protectors Location	65
Figure 5-22	LCD Screen (MMS Operation)	68

1 How to use this Manual

This manual is designed for ease of use, giving the user easy and quick reference to information. This manual uses notice icons to draw attention to the user important information regarding the safe operation and installation of the UPS. The notice icons used in this manual are explained below, and should be taken into account and adhered to whenever they appear in the text of this manual.



Warning: A warning symbol shows potentially hazardous situation or condition which could result in personal injury or death, if not avoided.



Caution: A caution symbol shows potentially hazardous situation or condition which could result in personal injury or equipment damage, if not avoided.



Note: A Note symbol shows the information the user or the service personnel should observe during the UPS operation or service work.



Prohibit: A prohibit symbol shows the act the user or the service personnel should NEVER perform during the UPS installation, operation or service work.

Safety Recommendations: If any problems are encountered while following this manual, Toshiba field service group assistance and correspondence is recommended.

2 INTRODUCTION

The Toshiba Uninterruptible Power Supply System (UPS) is designed to provide many years of reliable protection from power failure, brown-outs, line noise, and voltage transients. To ensure optimum performance of the equipment, follow the manufacturer's instructions. This manual contains descriptions required to operate the UPS. Please read this manual carefully and retain it for future reference.



CAUTION

IMPORTANT SAFETY INSTRUCTIONS

SAVE THESE INSTRUCTIONS

This manual contains important instructions for the G9000 SERIES Uninterruptible Power Supply Systems that should be followed during installation and maintenance of the UPS and batteries.



WARNING

WARNING 1

Lethal voltages exist within the equipment during operation. Observe all warning and cautions in this manual. Failure to comply may result in serious injury or death. Obtain qualified service for this equipment as instructed.



WARNING 2

In no event will TOSHIBA be responsible or liable for either indirect or consequential damage or injury that may come from the misuse of this equipment.



Don't modify the UPS entirely or partially.
Any modifications without authorization by TOSHIBA could result in personal injuries, death or destruction of the UPS.

2.1 SAFETY PRECAUTIONS

APPLICATION

This UPS shall NOT be applied to support equipment (*) that could affect human lives.



- * • Life support equipment in operating rooms (artificial dialysis, incubators, etc.)
- Toxic gas or smoke eliminators
- Equipment that must be provided under fire laws, construction standards or other ordinances
- Equipment equivalent to the above

Special considerations are required when applying this UPS to the equipment () that affect human safety and/or maintain public services.**



- ** • Equipment to supervise or control airways, railways, roads, sea-lanes or other transportation.
- Equipment in nuclear power plants.
- Equipment to control communications.
- Equipment equivalent/similar to the above mentioned.



NOTE

WARNING 3

The UPS is to be installed in a controlled environment.

Improper storage and installation environment may deteriorate insulation, shorten component life and cause malfunctions.

Keep the installation environment per standard described as follows:

Table 2-1 UPS Installation Environment

No.	Item	Environment standard	
1	Installation location	Indoors	
2	Ambient temperature	Minimum temperature: 32 °F(0 °C), Maximum temperature: 104 °F(40 °C) The average temperature over any 24-hour period must be in the range 41 °F (5 °C) to 95 °F(35 °C).	
3	Relative humidity	The relative humidity must be held between 5 and 95%. There must be no condensation due to temperature changes.	
4	Altitude	This equipment must not be applied at altitude that exceeds 2250m (7380ft) above sea level.	
5	Dust	Dust in the room where the UPS is installed must not exceed normal atmospheric dust levels. In particular, that dust should not include iron particles, oils or fats, or organic materials such as silicone.	
6	Inflammable gas following IEC654-4 Part 4	There should be no inflammable/explosive gas.	
		Hydrogen sulfide (H ₂ S)	No more than 0.003 PPM
		Sulfurous acid gas (SO ₂)	No more than 0.01 PPM
		Chlorine gas (Cl ₂)	No more than 0.002 PPM
		Ammonia gas (NH ₃)	No more than 1 PPM
		Nitrous oxides (NO _x)	No more than 0.05 PPM
		Ozone (O ₃)	No more than 0.002 PPM



NOTE

WARNING 4

This UPS does not include a Bypass input circuit breaker (MCCB) to protect the bypass circuit. The Bypass input circuit breaker (MCCB) is to be field supplied and installed. Recommended Breaker (MCCB)'s Specifications are as follows:

Table 2-2 Rating of Bypass Input Circuit Breaker

Capacity (kVA)	Bypass Voltage (Vac)	Bypass Rating (Aac)	Breaker (A)
100	480	120	150
160	480	192	250
225	480	271	350
300	480	361	500
500	480	601	800
650	480	782	1000
750	480	902	1200

AC input and AC output overcurrent protection and disconnect devices shall be field supplied and installed. The DC circuit breaker (MCCB) shall be field supplied and installed. The overcurrent protection device should be installed in the Battery cabinet and rated as indicated in Table 3-8.

Note: The DC input overcurrent protection (Battery disconnect breaker) hereinafter will be referred as “CB2”.

3 GENERAL

The Toshiba G9000 UPS is designed to provide continuous and clean electrical power to a critical load. Additionally the UPS monitors power conditions affecting the load. In the event of an input power failure, the UPS will supply power to the critical load for the specified battery time.

If the input power is not restored promptly, backup power from the UPS battery permits the orderly shutdown of equipment supported by the UPS. The UPS is simple to start-up, operate and maintain.

The G9000 SERIES UPS is available in seven kVA sizes - 100, 160, 225, 300, 500, 650, and 750 kVA. Specifications for each kVA model appear in Section 3.3. The principles of operation described herein are applicable to all models.

This manual provides an overview of the G9000 SERIES components and their functions. The appearance and purpose of operator controls and indicators is described with procedures for operation, start-up, shutdown and basic maintenance included.

3.1 DEFINITIONS

UNINTERRUPTIBLE POWER SUPPLY SYSTEM (UPS) – All components within the UPS Module Cabinet and associated batteries that function as a system to provide continuous, conditioned AC power to a load. This is sometimes referred to as the "System".

UPS MODULE CABINET – The metal enclosure which contains the Converter / Charger, Inverter, Static Transfer Switch, Internal Bypass line, operator controls, and internal control systems required to provide specified AC power to a load.

UPS MODULE – The Converter / Charger and Inverter assemblies which, under the direction of the internal control system and operator controls, provide specified AC power to a load.

INVERTER – The UPS components which contain the equipment and controls necessary to convert DC power from the Converter / Charger, or the battery, to AC power required by the critical load.

CONVERTER / CHARGER – The UPS components which contain the equipment and controls necessary to convert input AC power to regulated DC power required for battery charging and for supplying power to the Inverter.

STATIC TRANSFER SWITCH – The device which connects the critical load to the bypass line when the Inverter cannot supply continuous power.

BYPASS LINE – The line which conducts electricity directly from the input power source to the critical load during Maintenance or whenever the UPS is not completely operational.

AC INPUT POWER – Power provided by the electrical utility company, or auxiliary generator, which is connected to the UPS for supplying the critical load.

BATTERY – The rechargeable battery strings which supply DC power to the inverter to maintain continuous AC power to the load during AC input power failure conditions.

3.2 OPERATION OVERVIEW

The UPS provides two power paths between the utility source and the critical load.

Figure 3-1 shows the path for normal operation, with the load powered by the inverter.

Figure 3-2 shows the path for bypass operation, with the load supplied through the static bypass line.

3.2.1 Normal operation: Load power supplied by each system UPS inverter.

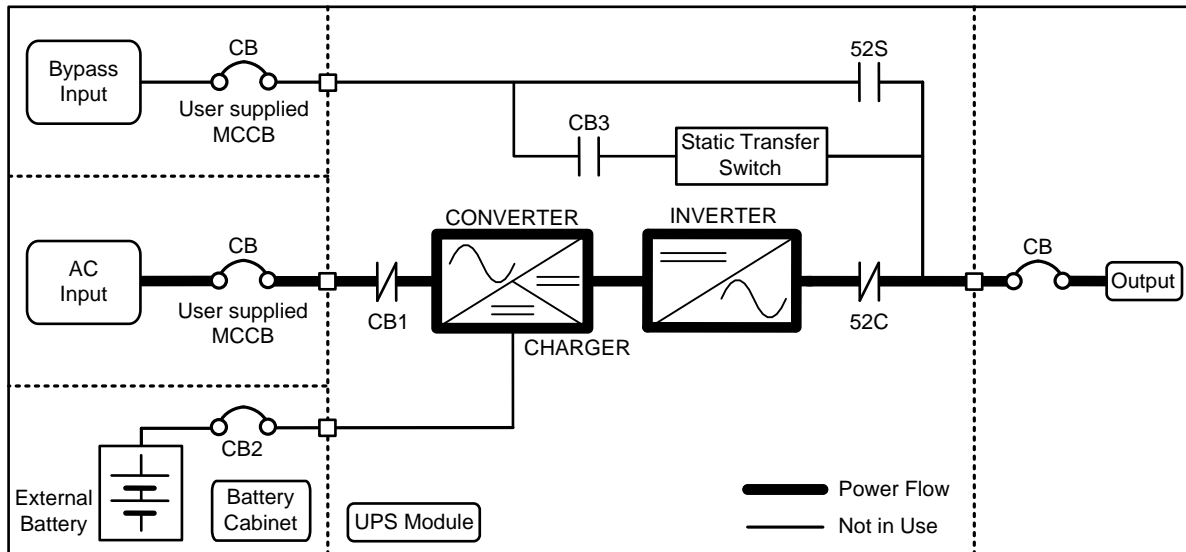

Figure 3-1 Single Line Diagram – Normal Operation: Load powered by UPS inverter

During normal operation, the path through the UPS inverter is used to power the load.

In Figure 3-1 input AC power is converted to DC by the Converter. DC power is utilized to charge the UPS battery and to provide power to the Inverter. The Inverter converts the DC power to clean AC power to supply the critical load.

The conversion - inversion process eliminates any voltage transients or fluctuations existing in the input power before it reaches the critical load.

The power drawn by the critical load is equally shared between all UPS systems when multiple UPSs are in Parallel Operation. (Figure 5-12 shows a sample of Parallel Operation System Configuration.)

In the event of a UPS module failure during Parallel Operation, the critical load power will be continually supplied and shared by all other UPS.



The Bypass Input breaker and cables are to be supplied and installed by the user or the constructor. (See WARNING 4 on page 5)

NOTE

3.2.2 Bypass Operation: Load Power supplied through UPS internal static bypass line.

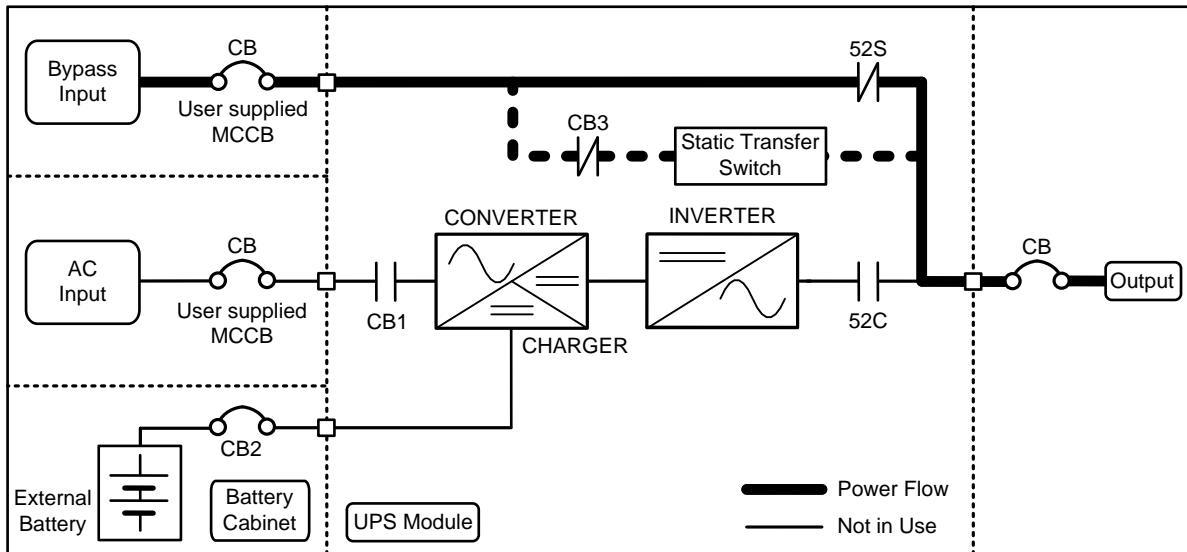

Figure 3-2 Single Line Diagram – Bypass Operation: Load fed through static bypass line.

Figure 3-2 shows the Internal Bypass line is a Hard-wired line through 52S which supplies the critical load with unconditioned bypass input power. Upon switching to the Internal Bypass line, the Static Transfer Switch line through CB3 (herein after STS contactor CB3) supplies the power immediately, and then the Internal Bypass line through 52S supplies the power. In the event of a switching to the Bypass line, the power to the critical load will be uninterrupted. The purpose of this Internal Bypass line is to route power to the critical load while the UPS module is de-energized (converter and inverter), and during Start-up before the system is fully operational.

Each UPS internal static bypass line will equally share the power supplied to the critical load whenever the system is in the Parallel Operation.

In the event of a load overcurrent, the UPS transfers to bypass without interruption to the critical load. In the case of the Parallel Operation, all UPS will transfer to bypass without interruption to the critical load.

The internal control system determines the operation of the two paths, with the load powered from the inverter being the normal operation.

3.2.3 Battery Operation: Load Power supplied by UPS battery.

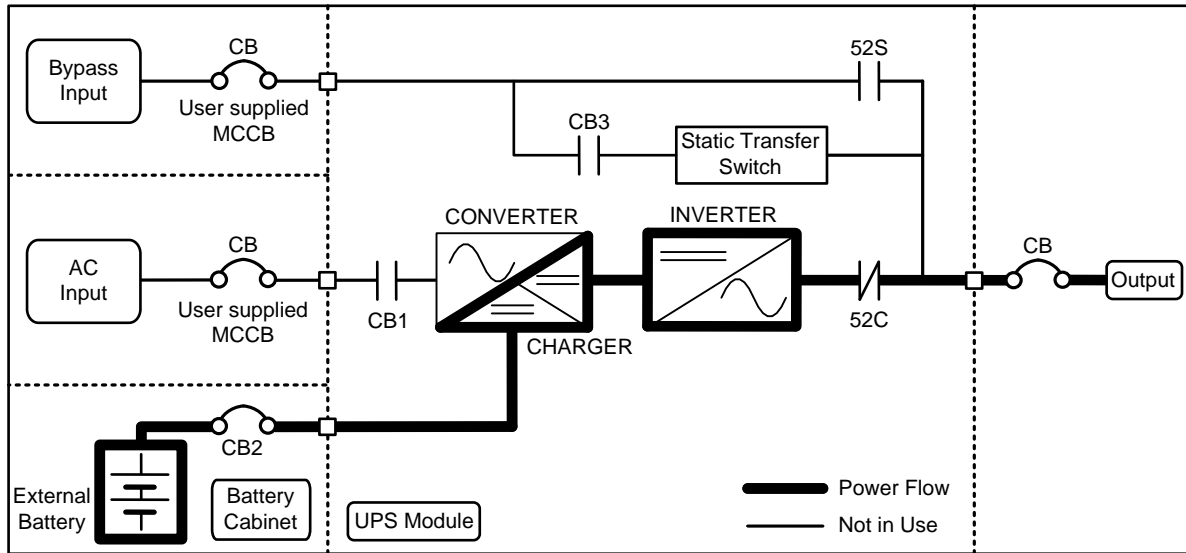

Figure 3-3 Single Line Diagram – Battery Operation

Figure 3-3 shows that in the event of AC input source failure or interruption, the UPS Converter(s)* will de-energize and the UPS battery(s)* will immediately discharge and supply DC power to the Inverter to maintain continuous AC power to the load. This operation will continue until:

- a) The battery capacity expires and the inverter turns off, or
- b) Input power is restored. (When input power is restored the converter will simultaneously power the inverter and critical load, and recharge the batteries.)

A fully charged battery will provide power for the specified time at the rated load, or longer, at a reduced load. (* (s): In the case of the Parallel Operation.)

When power is restored after a low battery shutdown, the UPS converter(s) automatically restarts operation, the charger(s) recharges the batteries and the Inverter(s) is automatically restarted without operator intervention. Load is automatically assumed by the inverter without operator intervention. (* (s): In the case of the Parallel Operation.)

The power drawn by the load is equally shared between all UPS regardless of the presence or absence of the UPS that is (are) in battery operation or not whenever the system is in the Parallel Operation.

3.2.4 UPS Parts Location.

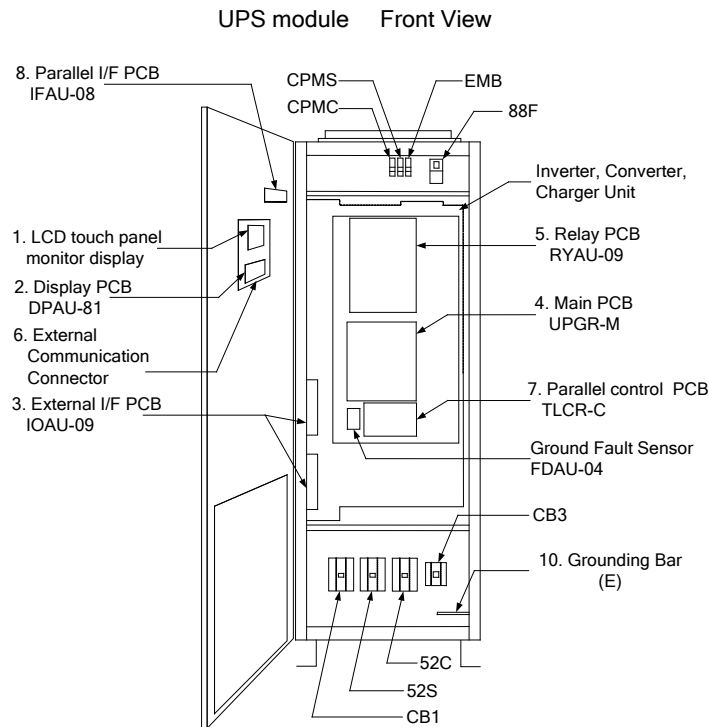

* Item 9 (AC input, AC output, DC input terminal) is not shown in Figure 3-4. (Refer to Figure 5-2)

Figure 3-4 UPS Parts Location (100kVA)

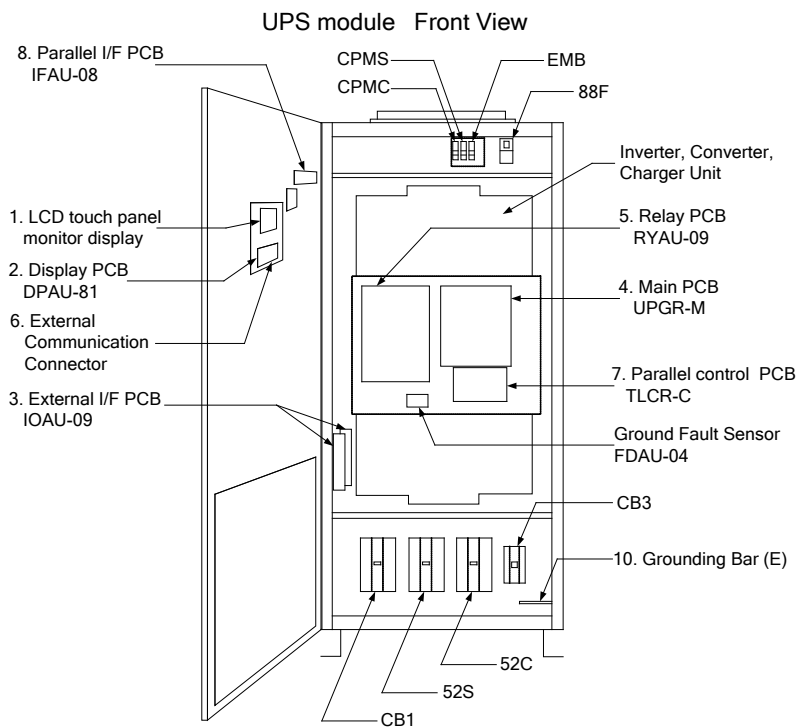

* Item 9 (AC input, AC output, DC input terminal) is not shown in Figure 3-5. (Refer to Figure 5-2)

Figure 3-5 UPS Parts Location (160, 225kVA)

Figure 3-6 UPS Parts Location (300kVA)

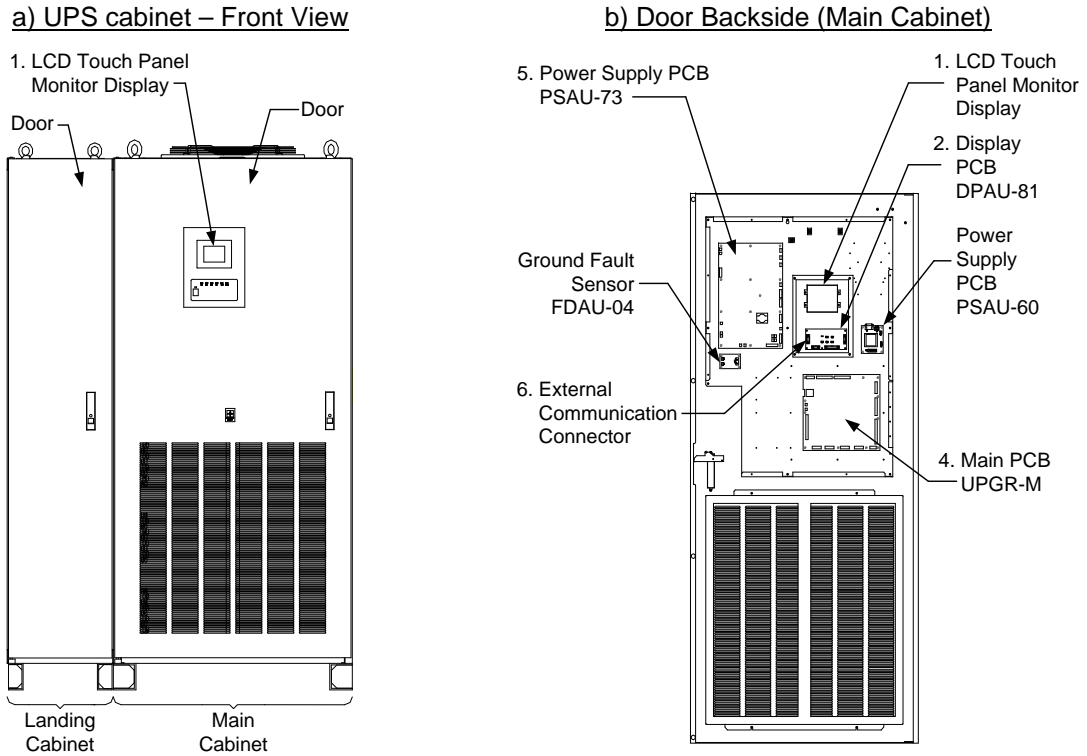

c) UPS cabinet – Front Inside View

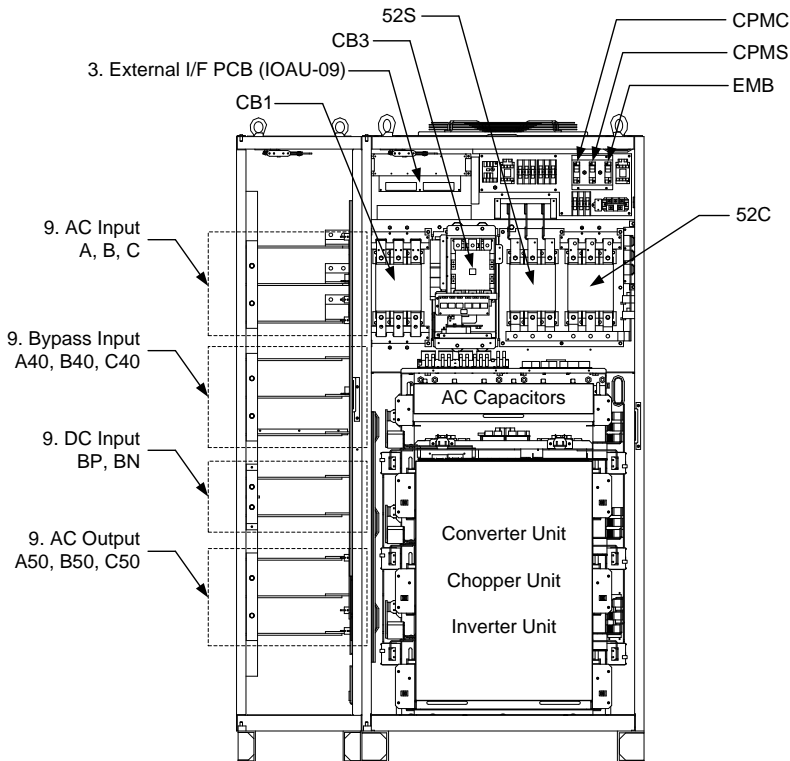

* Item 10 (Grounding bar) is not shown in Figure 3-6. (Refer to Figure 5-3).

Figure 3-7 UPS Parts Location (500kVA)

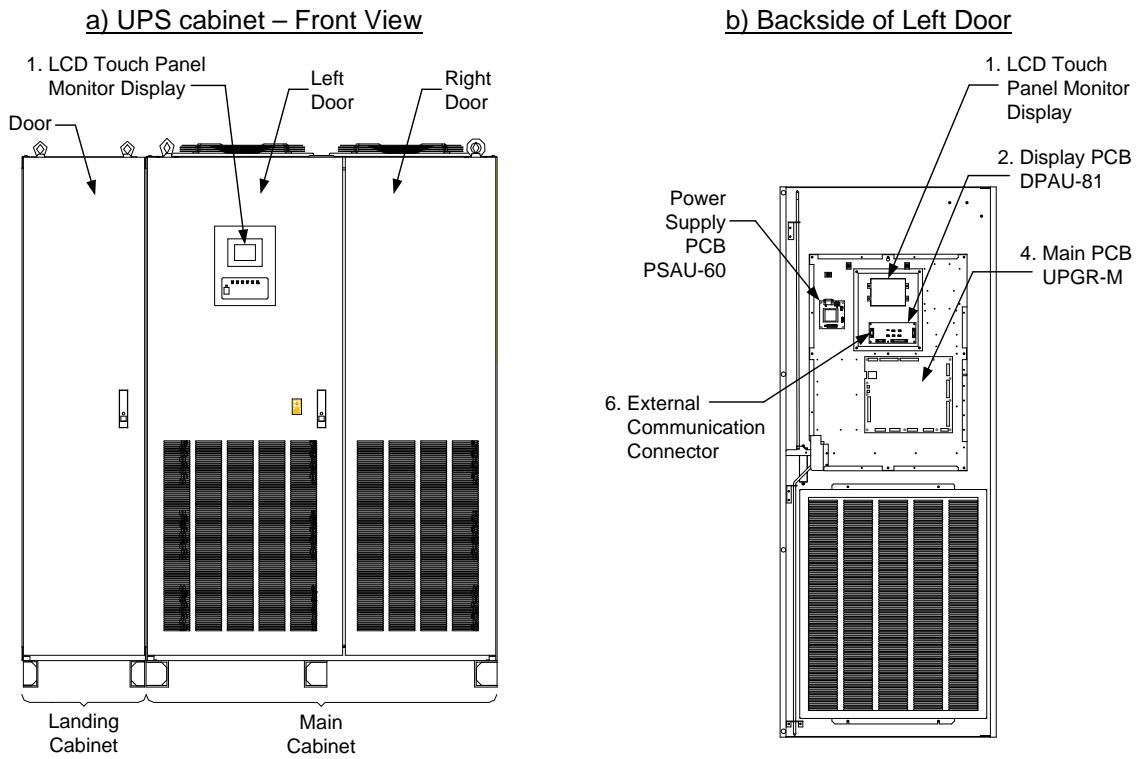

c) UPS cabinet – Front Inside View

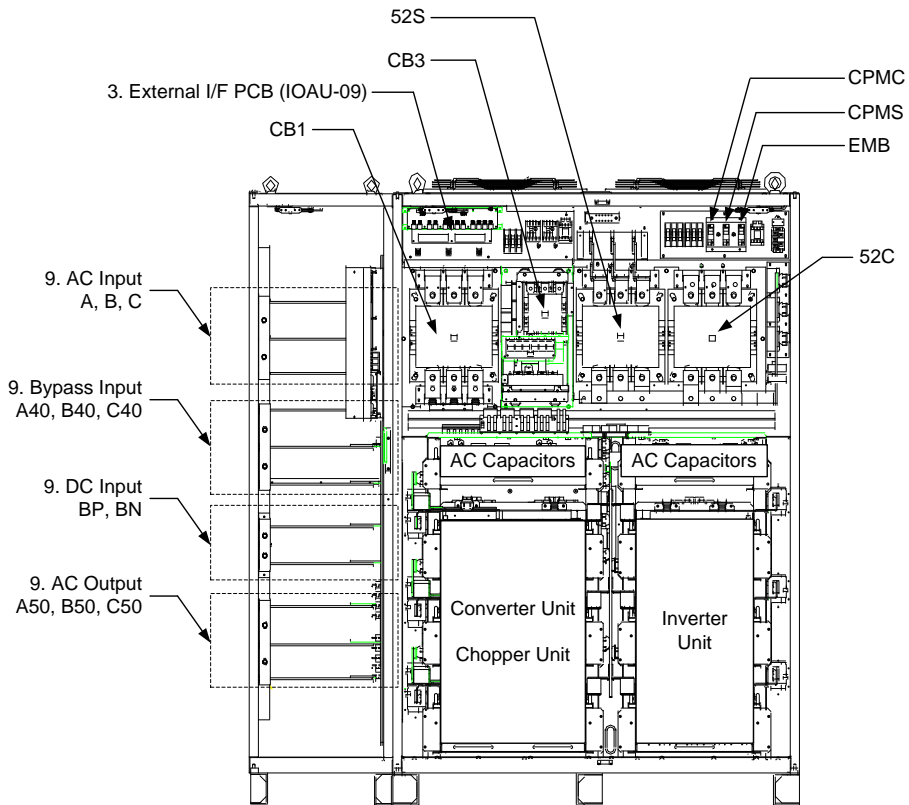

* Item 10 (Grounding bar) is not shown in Figure 3-7. (Refer to Figure 5-4).

Figure 3-8 UPS Parts Location (650kVA & 750kVA)

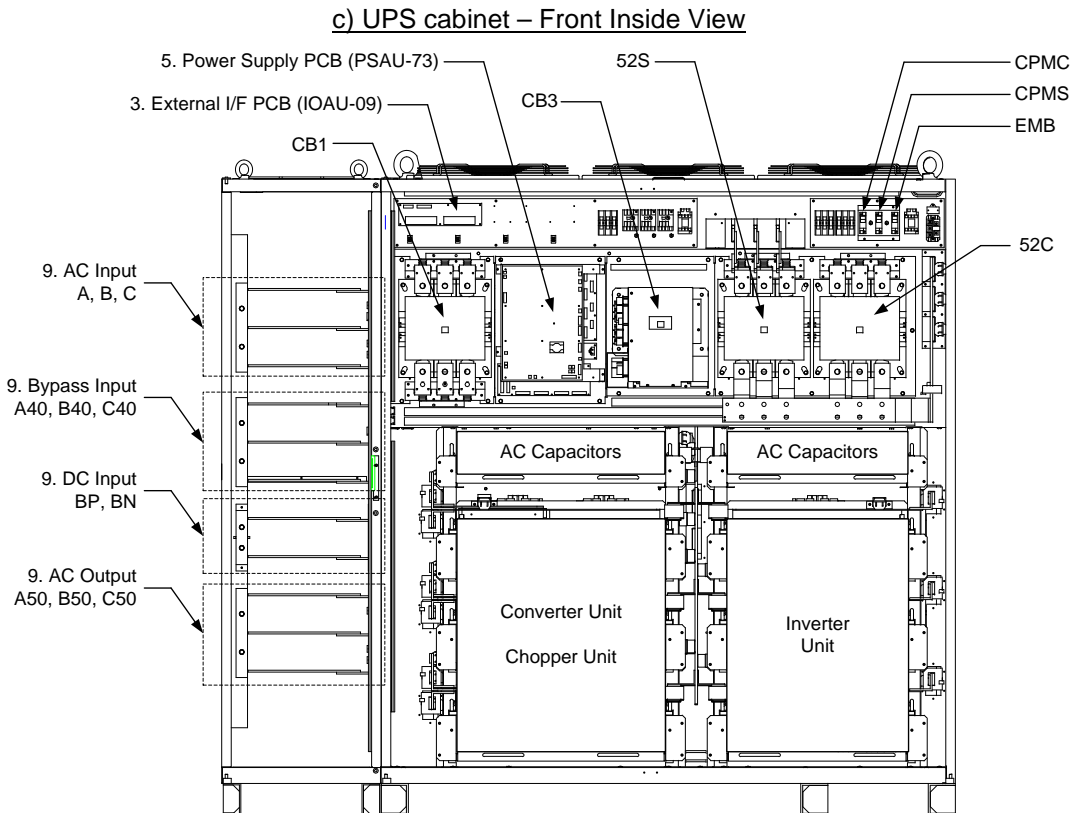
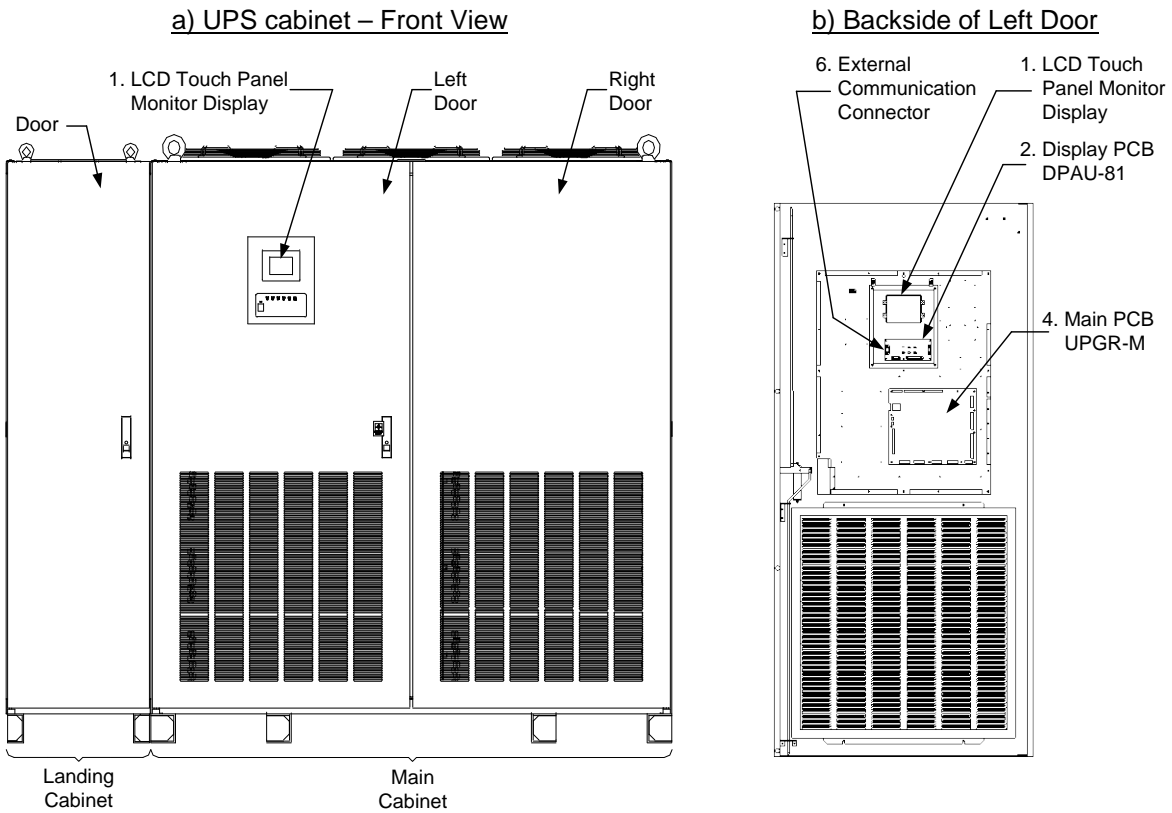

* Item 10 (Grounding bar) is not shown in Figure 3-8. (Refer to Figure 5-5).

Table 3-1 Circuit Breaker/Contactor Function

LABEL	FUNCTION
CB1	Converter Input Contactor
CB2*	*User Supplied External Batt Cabinet circuit breaker
CB3	Static Transfer Switch (STS) Contactor
52S	Bypass Contactor
52C	Inverter Output Contactor
CPMC	Control Power Supply Breaker (Normally ON) Provides power from converter input to CB1 coil.
CPMS	Control Power Supply Breaker (Normally ON) Provides power from bypass input to 52S coil.
EMB	Emergency Bypass Breaker (Normally OFF) Turns ON/OFF bypass contactor without main control signal.

3.2.5 PCB Layouts.

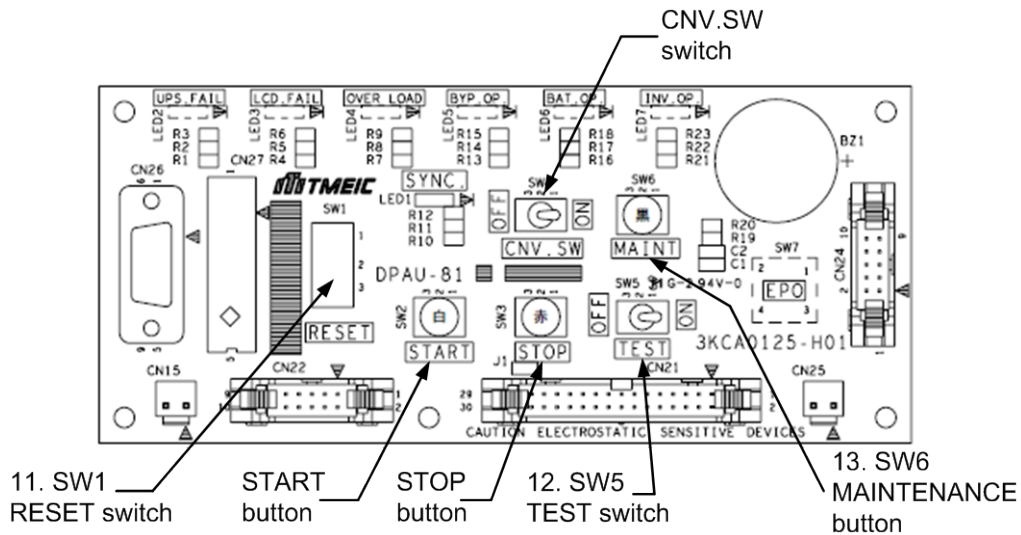

Figure 3-9 Display PCB DPAU-81

Table 3-2 DPAU-81 Switch/Button Function

LABEL	NAME	FUNCTION
SW1	Reset Switch	
START	START Button	
STOP	STOP Button	
TEST	SW5 Test Switch	
MAINT	SW6 Maintenance Button	
CNV. SW	Converter Switch	

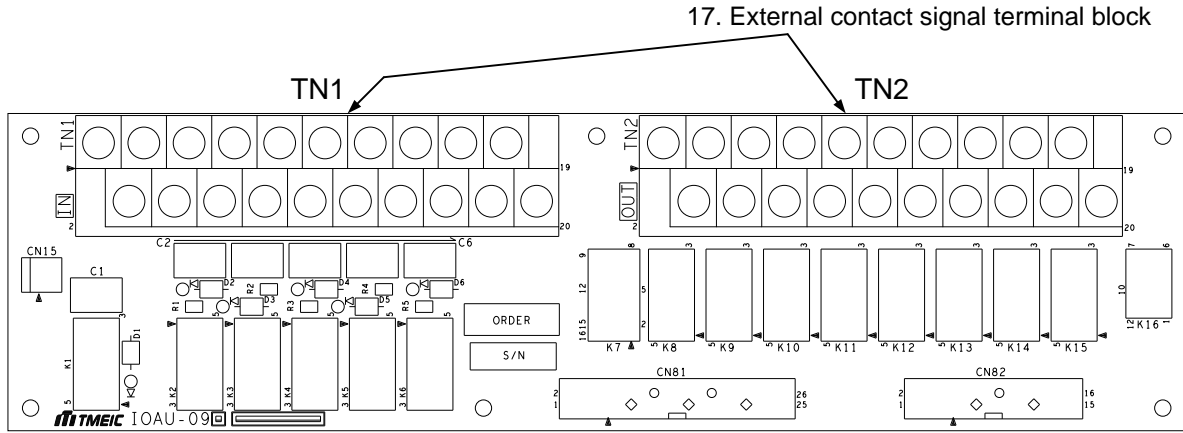

Figure 3-10 External I/F PCB IOAU-09

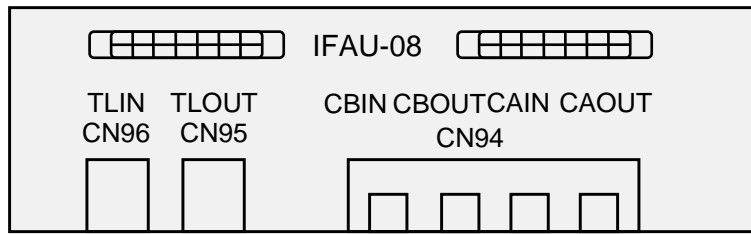

Figure 3-11 Parallel I/F PCB IFAU-08 (100-225kVA)

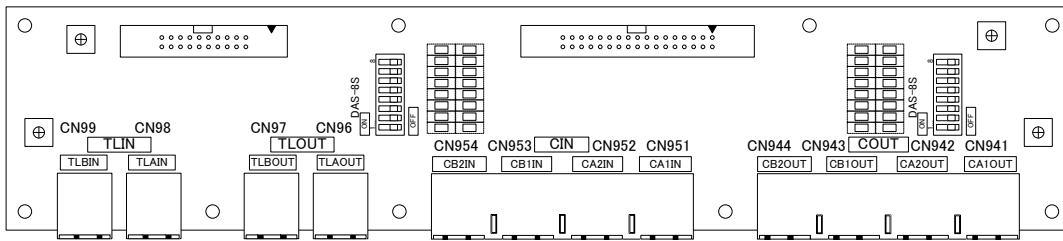
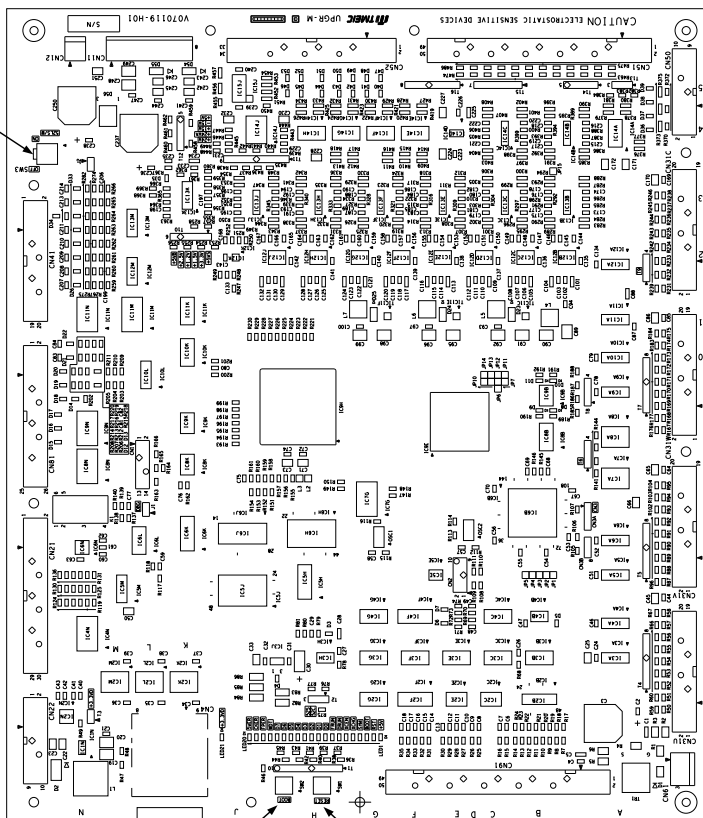

Figure 3-12 Parallel I/F PCB IFAU-09 (300-750kVA)

15. SW3
52L S/W switch



14. SW2
BOOT switch

11. SW1
RESET switch

Figure 3-13 MAIN PCB UPGR-M

Description of Figures Figure 3-9 to Figure 3-13

1. **LCD Touch Panel Monitor Display**

The Liquid Crystal Display (LCD) Touch Panel Monitor Display indicates power flow, measured values and fault and error messages via user selectable display screens.

Refer to Figure 4-1 for details.

2. **Display PCB DPAU-81 (Figure 3-9):**

Switches on DPAU-81 board (FOR SERVICE PERSONNEL ONLY)

- (11) SW1 (RESET switch)
- (12) SW5 (TEST switch)
- (13) SW6 (MAINTENANCE switch)

3. **External I/F PCB IOAU-09 (Figure 3-10):**

Signal I/F on IOAU-09 board

- (17) External contact signal terminal block

Refer to FIGURE 2.10.1-2 for details.

4. **Main PCB UPGR-M (Figure 3-13):**
Switches on UPGR-M board (FOR SERVICE PERSONNEL ONLY)
 - (11) SW1 (RESET switch)
 - (14) SW2 (BOOT switch)
 - (15) SW3 (52L S/W switch)
5. **a) Relay PCB RYAU-09 (100-225kVA)**
b) Power Supply PCB PSAU-73 (300-750kVA)
6. **External Communication Connector**
RS232C connector on DPAU-81 board (FOR SERVICE PERSONNEL ONLY)
Refer to FIGURE 2.18 for details.
7. **Parallel control PCB (not shown)**
 - a) **TLCR-C (100-225kVA)**
 - b) **TLCR-E (300-750kVA)****For use in Parallel Operation system application (Option)**
8. **Parallel I/F PCB IFAU-08**
 - a) **IFAU-08 (100-225kVA)**
 - b) **IFAU-09 (300-750kVA)****For use in Parallel Operation system application (Option - Figure 3-11 and Figure 3-12)**
Refer to Figure 5-15 to Figure 5-20 for details.
9. **AC input, AC output, DC input terminal**
Refer to Figure 5-2 to Figure 5-11 for details
10. **Grounding Bar (E)**
11. **"RESET" switch (FOR SERVICE PERSONNEL ONLY)**
This switch resets errors resulting from alarm conditions.
12. **"TEST" switch (FOR SERVICE PERSONNEL ONLY)**
This switch changes system operation to the test-mode.
13. **"MAINTENANCE" switch (FOR SERVICE PERSONNEL ONLY)**
This switch sets the UPS menu parameters.
14. **"BOOT" switch (FOR SERVICE PERSONNEL ONLY)**
This switch enables firmware to be loaded on the control board.
15. **"52L S/W" switch (FOR SERVICE PERSONNEL ONLY)**
This switch prohibits turning on the AC output contactor "52C" during test/maintenance in Parallel Operation system application.
16. **External contact signal terminal block**
Terminal block to connect contact signal input/output lines to and from external dry contacts. Refer to Figure 4-19 and Figure 4-21 for details.

3.3 SPECIFICATIONS

The UPS nameplate displays the rated kVA as well as nominal voltages and currents. The nameplate is located on the inside of the UPS front door.

Table 3–3 Power Specifications

Rated output Power	Input voltage 3 phase / 3 wire	Bypass input voltage 3 phase / 3 wire	Output voltage 3 phase / 3 wire
100kVA / 90 kW	480V	480V	480V
160kVA / 144kW	480V	480V	480V
225kVA / 202.5kW	480V	480V	480V
300kVA / 300kW	480V	480V	480V
500kVA / 500kW	480V	480V	480V
650kVA / 650kW	480V	480V	480V
750kVA / 750kW	480V	480V	480V

Table 3–4 UPS Module Information

a) Overall Dimension

UPS [kVA]	Width [in.] (mm)	Depth [in.] (mm)	Height [in.] (mm)	Net Weight [lbs.] (kg)	Typical Heating [kBTU/h]	Cable Knockout
100	27.6 (700)	32.8 (832)	80.6 (2,047)	855 (388)	13.5	BOTTOM
160	35.4 (900)	32.8 (832)	80.6 (2,047)	1,160 (526)	17.8	BOTTOM
225	35.4 (900)	32.8 (832)	80.6 (2,047)	1,230 (558)	25.1	BOTTOM
300	51.2 (1300)	32.7 (830.6)	80.7 (2,050)	2,260 (1,025)	31.7	BOTTOM/TOP/LEFT
500	70.9 (1800)	32.7 (830.6)	80.7 (2,050)	3,360 (1,525)	52.8	BOTTOM/TOP/LEFT
650	90.6 (2300)	32.7 (830.6)	80.7 (2,050)	4,250 (1,928)	79.2	BOTTOM/TOP/LEFT
750	90.6 (2300)	32.7 (830.6)	80.7 (2,050)	4,250 (1,928)	79.2	BOTTOM/TOP/LEFT

b) Packing Dimension

UPS [kVA]	Width [in.] (mm)	Depth [in.] (mm)	Height [in.] (mm)	Gross Weight [lbs.] (kg)
100	37.0 (940)	44.1 (1,120)	87.4 (2,220)	1,014 (460)
160	42.5 (1,080)	40.2 (1,020)	87.75 (2,229)	1,312 (595)
225	42.5 (1,080)	40.2 (1,020)	87.75 (2,229)	1,433 (650)
300	58.3 (1480)	40.2 (1020)	87.4 (2220)	2470 (1120)
500	78.3 (1990)	40.2 (1020)	87.4 (2220)	3700 (1678)
650 (Main Cabinet)	89.0 (2,260)	40.6 (1,030)	87.4 (2,220)	4,372 (1983)
650 (Landing Cabinet)	37.0 (940)	44.1 (1,120)	87.4 (2,220)	412 (187)
750 (Main Cabinet)	89.0 (2,260)	40.6 (1,030)	87.4 (2,220)	4,372 (1983)
750 (Landing Cabinet)	37.0 (940)	44.1 (1,120)	87.4 (2,220)	412 (187)

Table 3-5 Detail of Specifications

Rated Output kVA	100	160	225	300	500	650	750
Rated Output kW	90	144	202.5	300	500	650	750
AC INPUT							
Configuration	3 phase, 3 wire						
Voltage	480 V (+15% to -20%)						
Frequency	60 Hz (+/-10%)						
Power Factor	>.99 Lagging at 25% – 115% Load						
Input kVA (Max Input kVA)	95 kVA (107 kVA chg)	151 kVA (170 kVA chg)	212 kVA (238 kVA chg)	312 kVA (336 kVA chg)	521 kVA (560 kVA chg)	677 kVA (731 kVA chg)	781 kVA (840 kVA chg)
Walk-in Function	1 –30 Seconds (in 1 second increments)						
Start-up Delay	1 –3600 seconds (selectable in 1 second increments)						
Input Current Limiter	~111% Full Load Input Current			~108% Full Load Input Current			
Reflected Current THDi	<3%Typical for loads >60%; <5% Typical for loads >50%					<3%Typ for loads >70%; <5% Typ for loads >60%	<3%Typ for loads >60%; <5% Typ for loads >50%
Input Current (Max Input Current)	114 A (129 A)	181 A (204 A)	255 A (286 A)	376 A (404 A)	626 A (673 A)	814 A (879 A)	939 A (1010 A)
No-Load Static Loss	1.17 kW	1.56 kW	1.86 kW	2.57 kW	3.81 kW	5.4 kW	5.4 kW
STATIC BYPASS INPUT							
Configuration	3 phase, 3 wire						
Frequency	60 Hz ±5%						
Voltage	480 V ±10%						
Bypass Overload	1000% for 1 cycle			500% for 1 cycle			
BATTERY							
Type	Lead Acid						
Ride Through	Application Specific						
Nominal Voltage	480 Vdc						
Minimum Voltage	400 Vdc						
Float Voltage	Up to 545 Vdc						
DC Ripple Current (w/o batteries)	9 Adc	11 Adc	18 Adc	19 Adc	32 Adc	48 Adc	48 Adc
DC Ripple Current (% of Full Load DC Current)	3.8%	2.9%	3.4%	2.7%	2.7%	2.7%	2.7%
Max DC Charge Current	25 A	40 A	56 A	75 A	125 A	162 A	187 A

Rated Output kVA	100	160	225	300	500	650	750
Max. Discharge Current	235 A	372 A	524 A	776 A	1292 A	1677 A	1935 A
Batt. Capacity Required at Full Load Output	94 kWb	149 kWb	210 kWb	311 kWb	518 kWb	672 kWb	776 kWb
Number of Cells	240						
AC OUTPUT							
Configuration	3 phase, 3 wire						
Voltage	480 V						
Voltage Regulation	±1% (0 – 100% balanced load); ±2% (0 – 100% unbalanced load)						
Voltage Adj. Range	± 5.0% (in 0.5 V increments)						
Voltage Unbalance	2% maximum at 100% unbalanced load						
THD (V _{OUT})	< 2% THD at 100% linear load; < 5% THD at 100% nonlinear load						
Crest Factor	2.3						
Transient Response	±2% maximum at 100% load step; ±1% maximum at loss/return of AC power; ±5% maximum at load transfer to/from static bypass						
Transient Recovery Time	Less than 20ms						
Output Current	120 A	192 A	271 A	361 A	601 A	782 A	902 A
Number of Cells	240						
AC OUTPUT							
Frequency	60 Hz						
Frequency Synch. Range	±1% to ± 5% (selectable in 1% increments)						
Frequency Slew Rate	1 Hz/s to 5 Hz/s (selectable in 1 Hz/s increments)						
Frequency Regulation	±0.01% in free running mode						
Phase Displacement	±1° @ 100% Balanced Load; ±3° @ 100% Unbalanced Load						
Power Factor	0.9 (0.9 Lag to 0.95 Lead within output kW rating)			Unity			
Overload Capacity	125% for 2 minutes; 150% for 60 seconds			125% for 10 minutes; 150% for 60 seconds			
ENVIRONMENTAL							
Withstand Rating	65,000 A (with optional fuses)			100,000 A (with optional fuses)			
Cooling (Forced Air)	2892 cfm (1365 l/s)			5794 cfm (2730 l/s)		8676 cfm (4098 l/s)	
Operating Temperature	32 °F to 104 °F (0 °C to 40 °C). Recommended : 68° F to 86° F (20 °C to 30 °C)						
Relative Humidity	5% – 95% Non-Condensing						
Altitude	0 to 7380 ft. (2250 m) No Derating at 40° C						
Location	Indoor (free from corrosive gases and dust)						
Paint Color	Munsell N1.5 (Black)						

Rated Output kVA	100	160	225	300	500	650	750
Clearance Required	Top: 20 in. (508 mm); Front: 40 in. (1016 mm); Rear: 0 in. (0 mm); Sides: 0 in. (0 mm) if sidecars used, 1 in. (25 mm) if no sidecars used.			Top: 23.6 in. (600 mm); Front: 42.3 in. (1075 mm); Rear: 0 in. (0 mm); Sides: 0 in. (0 mm) if sidecars used, 1 in. (25 mm) if no sidecars used.			
Enclosure	NEMA 1						
Audible Noise	70 dB @ 1 m			73 dB @ 1 m			
Listings/Standards	ENERGY STAR® certified UPS, UL 1778; cUL; FCC Class A-Article 47 – Part 15 B; ISO 9001; ISO14001; ANSI C62.41 (IEEE 587 Cat. B)			ENERGY STAR® certified UPS, UL 1778; cUL; IEC 62040-2 Cat. C3; ISO 9001; ISO14001; ANSI C62.41 (IEEE 587 Cat. B)			
Warranty	3 Years Parts and Labor						
Emergency Power Off	Included						
MONITORING							
Dry Contacts Included	Yes, for Input and Output Signals						
RS232 Port	Included						
Intelligent Monitoring (Optional)	SNMP; MODBus RTU; MODBus TCP; BACNET; METASYS						
Display	LCD Touch Panel for Local Monitoring, Operation, and Control						

Table 3-6 Typical UPS Efficiencies at Various Loads

UNIT	% Full Load				
	20%	40%	60%	80%	100%
100 kVA	92.5%	94.3%	95.0%	95.2%	95.8%
160 kVA	94.7%	95.7%	96.2%	96.5%	96.5%
225 kVA	94.9%	96.2%	96.5%	96.5%	96.5%
300 kVA	94.4%	96.3%	96.9%	97.0%	97.0%
500 kVA	94.8%	96.7%	97.0%	97.0%	97.0%
650 kVA	95.4%	96.5%	97.0%	97.0%	97.0%
750 kVA	95.5%	96.6%	97.0%	97.0%	97.0%

Table 3-7 MTBF and MTTR

Parameter	100-225kVA	300-750kVA
MTBF (Mean Time Between Failures): System (With Bypass)	3,081,946 hr.	2,633,910 hr.
Inverter (Without Bypass)	140,406 hr.	101,687 hr.
MTTR (Mean Time to Repair) – Excluding Travel and Shipping Time)	4 hr.	1.5 hr.

Table 3-8 Rating of Contactors, Breakers and Fuses

	NUMBER	APPLICATION	OUTPUT CAPACITY OF EQUIPMENT						
			100kVA	160kVA	225kVA	300kVA	500kVA	650kVA	750kVA
			90kW	144kW	202.5kW	300kW	500kW	650kW	750kW
Contactor	CB1	AC input contactor	135A	200A	285A	452A	680A	1005A	1005A
	CB3	STS contactor	80A	135A	150A	260A	260A	350A	350A
	52C	Inverter output contactor	135A	200A	285A	452A	680A	1005A	1005A
	52S	Bypass contactor	135A	200A	285A	452A	680A	1005A	1005A
	88RC	Control circuit contactor	20A	20A	20A	20A	20A	20A	20A
Breaker	CB2	Battery disconnect breaker (Recommended)	300A	400A	600A	800A	1400A	2000A	2000A
	User supply (OPTION)	AC input breaker (Recommended)	150A	250A	350A	500A	800A	1200A	1200A
	User supply (OPTION)	AC bypass breaker (Recommended)	150A	250A	350A	500A	800A	1000A	1200A
	User supply (OPTION)	AC output breaker (Recommended)	150A	250A	350A	500A	800A	1000A	1200A
Fuses	FCU, FCV, FCW FCR, FCS, FCT	DC fuse	315A / 690V	200A / 690V	200A / 690V	450A / 690V	630A / 690V	800A / 690V	800A / 690V
	FPU, FPV FNU, FNV	DC fuse	200A / 690V	350A / 690V	350A / 690V	450A / 690V	630A / 690V	800A / 690V	800A / 690V
	FPR, FPS, FPT, FPW, FNR, FNS, FNT, FNW	DC fuse	-	-	-	450A / 690V	630A / 690V	800A / 690V	800A / 690V
	FUA, FUB, FUC	Control power fuse	30A / 600V	30A / 600V	30A / 600V	30A / 600V	30A / 600V	30A / 600V	30A / 600V
	(OPTION) FSU, FSV, FSW	Bypass input fuse	250A / 690V	200A / 690V	250A / 690V	250A / 690V	315A / 690V	315A / 690V	315A / 690V
	FZS1, 2, 3	Bypass input ZNR fuse	5A / 500V	5A / 500V	5A / 500V	-	-	-	-
	FBS1, 2, 3	Control power fuse	30A / 600V	30A / 600V	30A / 600V	30A / 600V	30A / 600V	30A / 600V	30A / 600V
	FZR1, 2, 3	AC input ZNR fuse	5A / 500V	5A / 500V	5A / 500V	-	-	-	-
	FEA, FEB, FEC	Parallel control circuit fuse	3A / 600V	3A / 600V	3A / 600V	3A / 600V	3A / 600V	3A / 600V	3A / 600V

4 OPERATOR CONTROLS AND INDICATORS

The G9000 Series operator controls and indicators are located as follows (Door exterior):

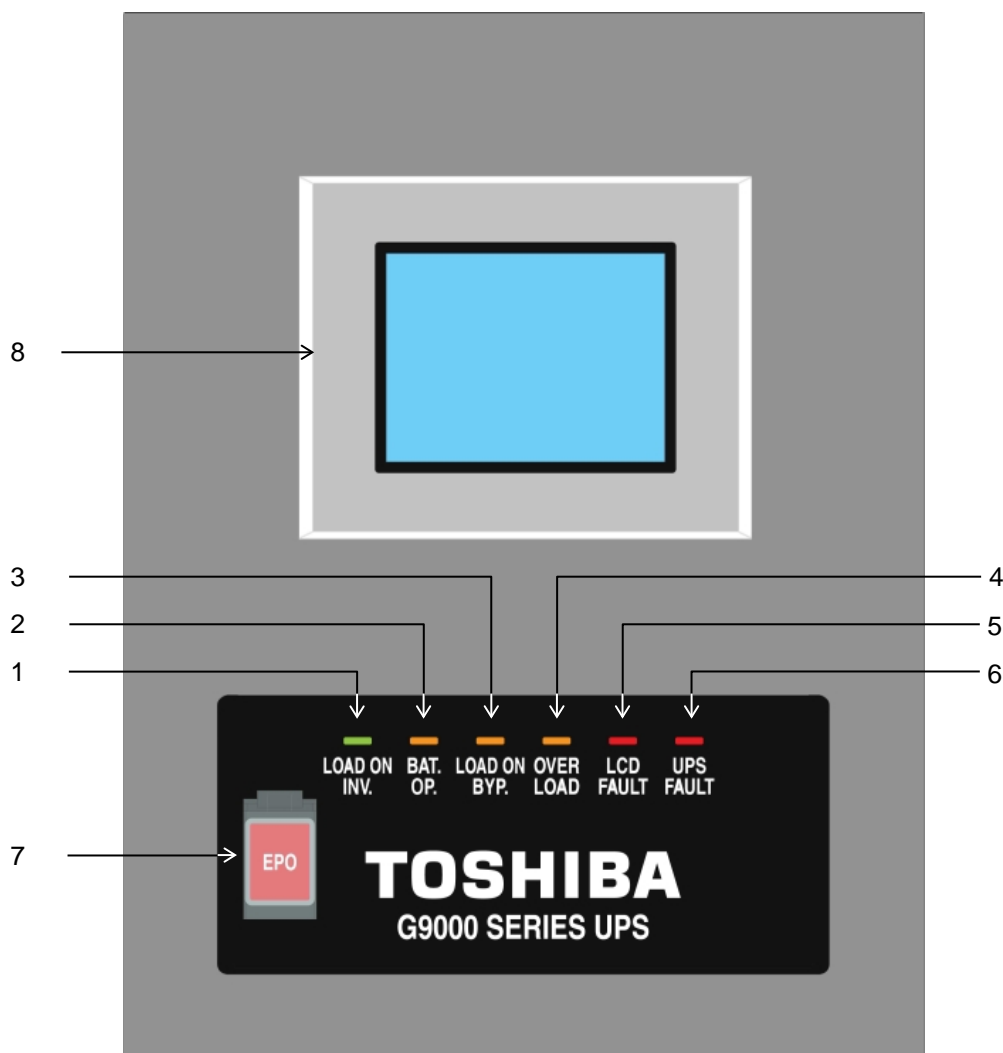

Figure 4-1 Operation/Display Panel (Front panel)

4.1 LED DISPLAY

1) **Load on inverter [LOAD ON INVERTER] (green)**

Illuminates when power is supplied from inverter to the critical load.
(Indicates the state of inverter transfer switch "52C".)

2) **Battery operation [BATTERY OP.] (orange)**

Illuminates when power is supplied from batteries following a power failure.

3) **Load on bypass [LOAD ON BYPASS] (orange)**

Illuminates when power is supplied to load devices by static bypass.

(Indicates the state of bypass transfer switch "52S".)

4) **Overload [OVERLOAD] (orange)**

Illuminates in overload condition.

5) **LCD fault [LCD FAULT] (red)**

Illuminates when LCD is not responding.

6) **UPS fault [UPS FAULT] (red) [Annunciator: intermittent or constant tones]**

Illuminates when an error occurs in the system. In this case, the details of the error are

Indicated on the display panel.

4.2 EPO BUTTON (EMERGENCY POWER OFF BUTTON) (7)

When activated, the Emergency Power Off (EPO) function shuts down the UPS module. The critical load will lose power and also shutdown. The EPO function can be performed either locally or remotely.

4.3 LIQUID CRYSTAL DISPLAY (8)

The Liquid Crystal Display (LCD) touch panel indicates power flow, measured values, operational guidance, data records and error messages. The LCD panel has a back-light which facilitates viewing in different ambient lighting conditions. The LCD will automatically clear and turn off, if the screen is not activated within 3 minute period. The LCD is turned back on when it is touched again. The LCD ERROR indicator is cleared after 24 hours and can be reproduced by pressing any key on the panel.

4.3.1 Test Mode Options

Several parameters and functions are available if they are enabled by a Toshiba Field Representative while the UPS is in Test Mode.

4.3.1.1 Battery Equalize Charge

The UPS "Equalize Charge" parameter is disabled by default unless the unit is sold with a wet cell battery system.

The "Equalize Charge" button can be enabled by a Toshiba Service Representative while the UPS is in Test Mode (Battery Run Setup). Once enabled, the "Equalize ON/OFF" button is located under OPERATION / SETUP.

To Initiate the Equalize Charge battery function, press the "Equalize ON/OFF" button. Equalize Charge will boost the charge voltage (500-640V) for the length of time (0-100 hrs.) specified during setup.

4.3.1.2 Battery Self Check

The UPS "Battery Self Check" function provides a periodic battery self-check at preset intervals. The parameter is disabled by default.

The adjustable Self Check cycle ships with a default setting of 720hrs. The minimum interval is 5 hrs.

When the Self Check is initiated, the converter contributes 5% of the load to the inverter for up to 200ms. If the batteries cannot reach and contribute 5% of the load or if the battery voltage falls out of tolerance, the unit will end the test and set an alarm.

4.3.2 Menu

A) MAIN MENU (Figure 4-2)

The LCD panel indicates power flow and measured values, while also operating the start/stop function. The LCD panel also allows the user to verify the status and operation of the UPS Module.



LED: LOAD ON INV

Figure 4-2 Main Screen

The following will be displayed when the START/STOP key on the MAIN MENU is pressed (Jump into **OPERATION MENU**):

1) Startup/Shutdown Guidance (Figure 4-3 to Figure 4-5)

The display indicates the Startup and Shutdown guidance for the UPS system. If this operation is PIN protected, the user is required to enter the security PIN before the screen can be accessed.

When in remote mode, the message "REMOTE operating model" will appear on this Screen. The user cannot operate the start and stop functions without changing the setup from remote mode to local mode.

When bypass voltage is abnormal, the message "Bypass voltage abnormal" will appear.

-**Start:** When the bypass voltage is abnormal, the LCD asks the operator if an interrupted transfer is acceptable (Load may be lost).

-**Stop:** When the bypass voltage is abnormal, the user cannot transfer from inverter to bypass line.



Figure 4-3 Startup/Shutdown Guidance



Figure 4-4 Startup Guidance



Figure 4-5 Shutdown Guidance

Follow Startup/Shutdown guidance accordingly.

MEASUREMENT MENU (Figure 4-6 to Figure 4-8)

This screen shows details of measured values. Input and Output values are displayed. During Battery operation, remaining battery power and Run time are also displayed.



Figure 4-6 Input values



Figure 4-7 Battery Operation Values

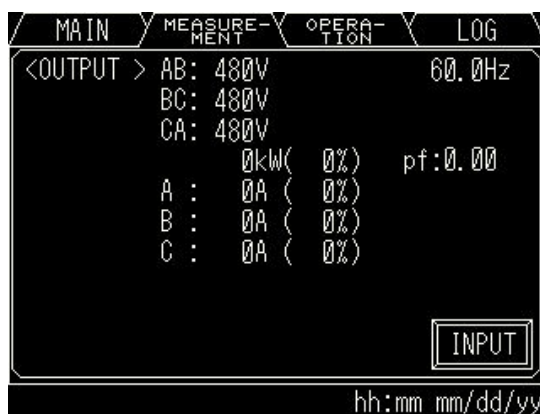

Figure 4-8 Output values

C) OPERATION MENU (Figure 4-9 to Figure 4-10)

This screen prompts the user to select: (a) whether the start & stop operation will be performed by local or remote operation; (b) date & time adjustment; (c) battery equalizing charge. The battery equalizing charge operation key will appear when battery equalizing charge is set up (Setup is based on battery type).

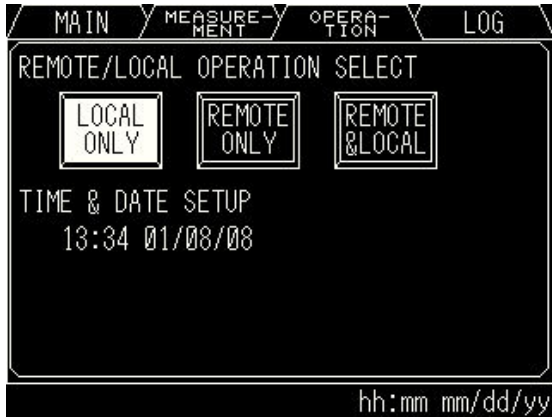

Figure 4-9 Remote/Local operation select

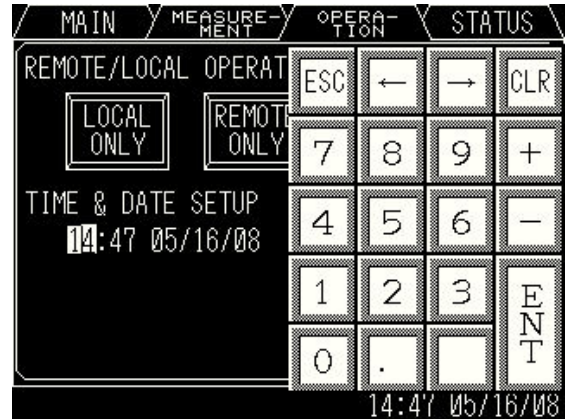

Figure 4-10 Date & Time adjustment

D) LOG MENU (Figure 4-11 to Figure 4-13)

This LOG MENU displays two Touch icons in EVENT LOG and BATTERY LOG.

Pressing the EVENT LOG icon, up to 50 condition/operation records will be displayed. Press ▲ or ▼ button for page turning.

Pressing the BATTERY LOG icon, Number of battery operations and Summed battery operation time are displayed.



Figure 4-11 Log menu



Figure 4-12 Event Log

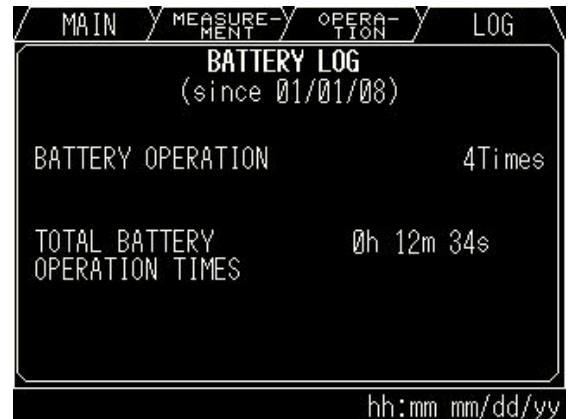

Figure 4-13 Battery log

4.3.3 Input Power Failure

During an Input Power Failure, the UPS inverter will be powered by the UPS batteries. The following will be displayed on the main and measurement screen (Indication of battery operation and remaining battery time).

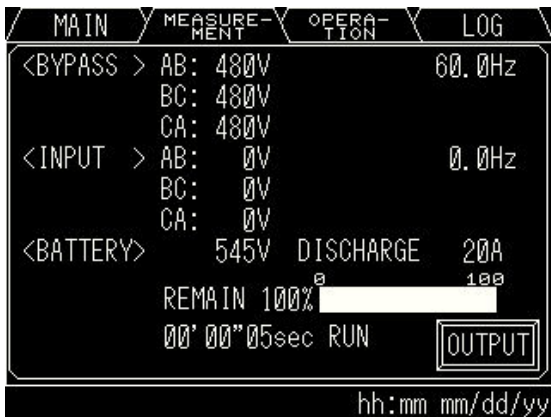

Figure 4-14 Main Screen (Battery Operation)



Figure 4-15 Measurement screen (Battery Operation)

The LCD will display a battery low voltage message when the battery capacity is near depletion. The End of Battery Discharge announcement is displayed when the battery end voltage is reached. At this time, the inverter will perform an electronic shutdown to prevent battery loss of life typical from extreme deep discharge conditions. When the input power is restored, the inverter will automatically restart to power the load, and the batteries will be simultaneously recharged. The End of Battery announcement is shown at the bottom of the screen.

4.3.4 Fault Indication

“MESSAGE” and “SILENCE ALARM” icons will appear on the main menu when UPS failure condition has occurred.



Figure 4-16 Main screen (Fault indication)

The following will be displayed when the MESSAGE icon on the main menu is pressed.

1) MESSAGE

The display shows a fault code, the description of the fault and a guidance of what action is to be taken by the user. A maximum of 10 faults are displayed at one time. If an input power failure occurs during a fault condition, the fault indication and input power failure announcement are alternatively displayed at 5 second intervals.

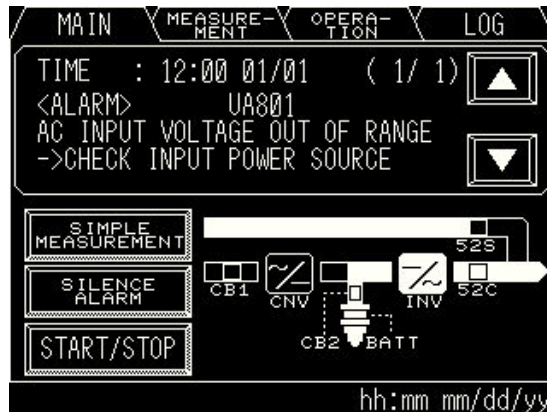

Figure 4-17 Message Screen

2) SILENCE ALARM

This icon will appear when a failure occurs. The audible alarm (announcing the failure) can be silenced by pressing this icon.

4.4 EXTERNAL AUX CONTACT INPUT AND OUTPUT TERMINAL BLOCKS

The UPS is equipped with terminals strips TN1 (Input) and TN2 (Output) on the Auxiliary Connection Board, IOAU-09. Some of these terminals are user-assignable to a variety of functions. These can be programmed to:

- Inputs (TN1): Control the UPS remotely, or report environmental data to the UPS.
- Outputs (TN2): Report status data from the UPS to external annunciation/monitoring devices.

4.4.1 Aux contacts - Input

The Input terminal provides four (IN1 thru IN4) programmable contacts (see) that can be set to any of the functions in Table 4-1.



PROHIBIT

*Do not apply voltages to remote access input terminals.
Damage to UPS may result.*

Inputs require a dry NO (Normally Open) contact to be wired on the corresponding terminals on TN1 of IOAU-09. Closing this contact activates the selected functionality set for that input. The Inputs provide a signal or "wetting" voltage of 24VDC / 8.3 mA. See Figure 4-19. The function takes effect immediately upon contact closure, and is removed immediately upon opening.

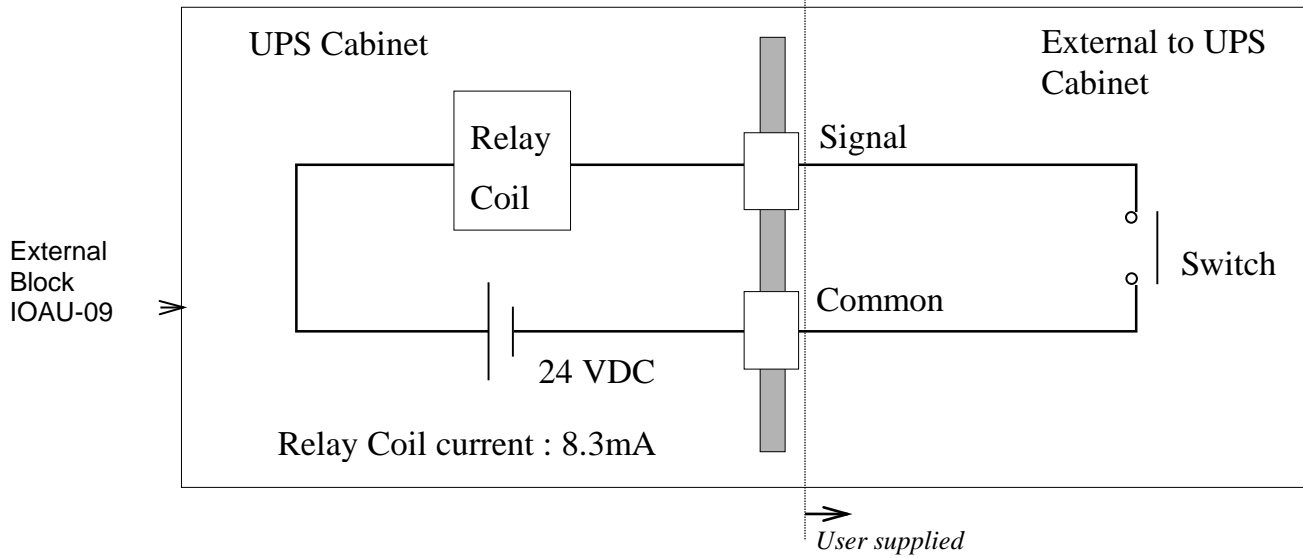

Figure 4-18 Control Wiring for Aux Input Contacts

See Figure 4.19, and Table 4-1.

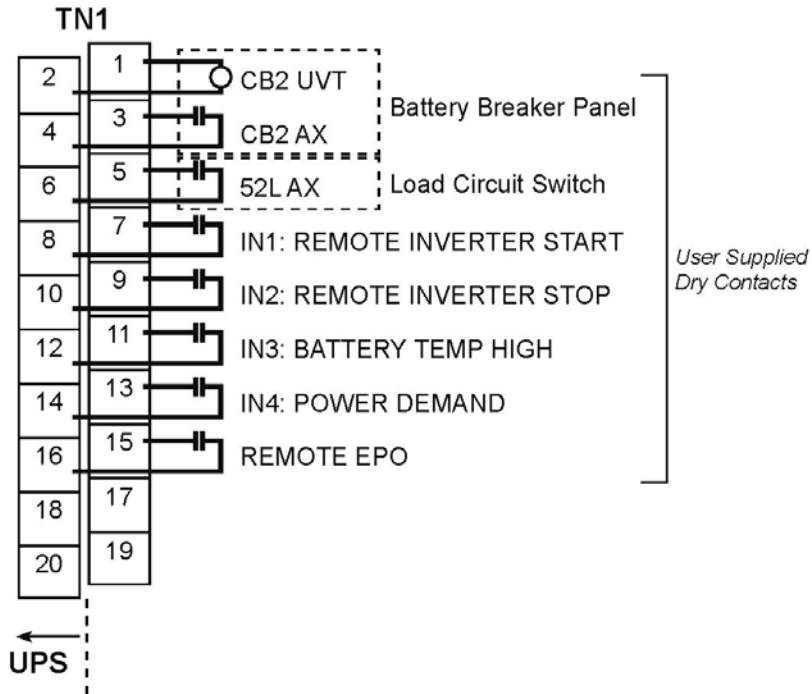

Figure 4-19 External Signal Input Terminal Block (with default settings)

The input logic can be reversed by setting the Active Level to "Neg" when selecting the input function. This will be annunciated on the Setup screen for the inputs by an "R" next to the Input Port.

For Example:

"IN1 1" indicates the UPS will remote start when contact closes.

"IN1 R1" indicates the UPS will remote start when contact opens.



In all cases, a switch having a protective cover is recommended in order to reduce the possibility of accidental operation.

Table 4–1 External Input Functions

Code	Function	Description
0	NONE	
1 *	REMOTE START	Starts UPS inverter from remote location. Use momentary (0.5 to 4 sec.) switches only. <i>This is the default setting on IN1</i>
2 *	REMOTE STOP	Stops UPS inverter from remote location. Use momentary (0.5 to 4 sec.) switches only. <i>This is the default setting on IN2</i>
3	POWER DEMAND 1	Driven by any customer-provided NO (Normally Open) dry contact. Closing the contact limits the input current to a value (10-150% of the UPS's rated input) set in the TEST MENU – "Power Demand Level 1" by an Authorized Toshiba Service Provider. Opening the contact returns the UPS to its normal operation parameters. <i>This is the default setting on IN4.</i>
4 *	POWER DEMAND 2	Driven by any customer-provided NO (Normally Open) dry contact. Closing the contact limits the input current to a value (10-150% of the UPS's rated input) set in the TEST MENU – "Power Demand Level 2" by an Authorized Toshiba Service Provider. Opening the contact returns the UPS to its normal operation parameters.
5	BATTERY LIQUID LOW	Annunciates "UF158 BATTERY LIQUID LOW", and is used with an electrolyte level sensor in a wet cell battery system.
6 *	BATTERY TEMP ABNORMAL	Driven by any customer-provided NO (Normally Open) dry contact thermal detection device installed in the UPS's Battery Cabinet(s). When the contact closes, the UPS decreases its battery charging maximum limit to 95% of the set charging voltage. If the contacts stay closed (the battery temp is still abnormal) for two hours, the UPS will shut off its battery charger. (Battery operation will still possible) <i>This is the default setting on IN3</i>
7	GENERATOR RUN	Inhibits transfer to bypass.
8	ASYNCHRONOUS	Inverter operates in free run mode. (In other words, inverter does not track bypass as sync source.)
9	ANOTHER BUS SYNC	Inverter will sync to an external source. For use with External Sync packages.
10	REMOTE INVERTER (MMS)	Starts all UPS inverters in an MMS system from a remote location.
11	REMOTE BYPASS (MMS)	Stops all UPS inverters in an MMS system from a remote location.
12	EXT.BYP dV STR	Inverter voltage is adjusted to match bypass voltage.
13	USE IB LIMIT 2	Use battery charge rate 2. This level is set in the TEST MENU by an Authorized Toshiba Service Provider.
14	CHARGER STOP	Battery charger will be stopped.
15	EXTERNAL ALARM	Annunciates "UA890 EXTERNAL ALARM".
16	CB2 EX	Provides for another aux battery breaker (CB2) contact, similar in function to the standard battery aux contact.
17	CHARGE DEVICE ERR	Energy storage device error signal. Mainly used with flywheels to annunciate recharge fault.
18	CB1 ON IL	Stops the rectifier converter remotely.

Code	Function	Description
31	TRACE TRIGGER	For use with the internal wave capture tool; for use by Authorized Toshiba Service Providers.

*Default Settings from Factory.

4.4.2 Aux Contacts - Output

The Output terminal strip TN2 provides eight (OUT1 thru OUT8) Form "A" NO (Normally Open) dry type programmable contacts to drive annunciation signals sourced or "wetted" by external monitoring devices. All output contacts are rated for NEC Class 2 operation (30VDC / 1ADC.)

The output dry contacts should be operated at their rated values or lower. Figure 4-20 illustrates a typical installation. The external relay can be a lamp, LED, computer, etc.

These contacts can be programmed to provide any of the functions in Table 4-2.

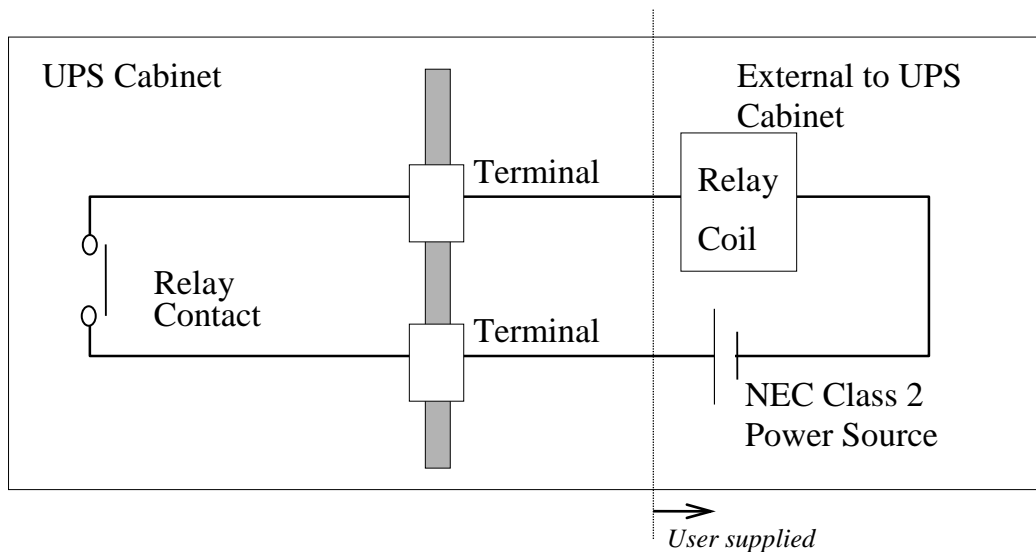

Figure 4-20 Control Wiring for Aux Output Contacts

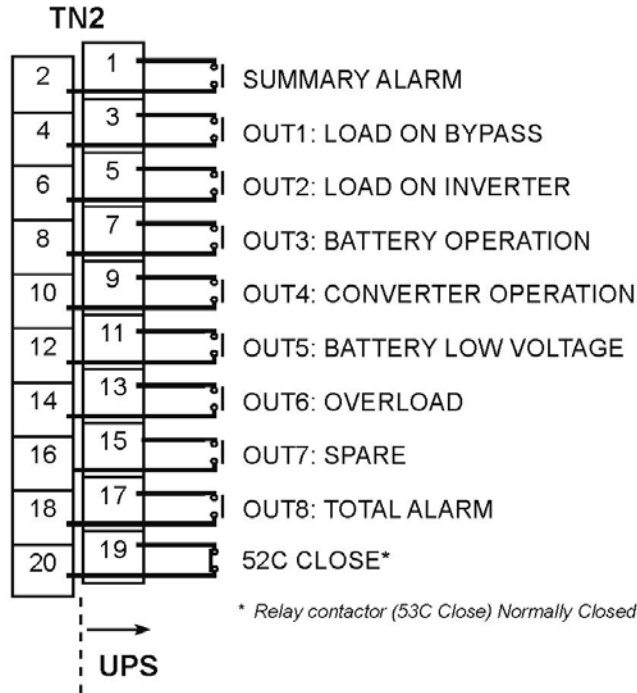

Figure 4-21 External Signal Output Terminal Block (with default settings)

These contacts can be programmed to provide any of the functions shown in Table 2.2. The default programmed values are indicated with an asterisk (*).

Table 4-2 External Output Functions

Code	Function	Description
0	NONE	
1 *	TOTAL ALARM	Summary alarm; activated when any minor, major, fault or alarm has occurred with the system. <i>This is the default setting on OUT8.</i>
2 *	MINOR FAULT	Activated when a minor fault has occurred with the system.
3	ALARM	Activated when an alarm has occurred with the system.
4	AC INPUT ABNORMAL	Activated when the input voltage or frequency is abnormal.
5	BYPASS ABNORMAL	Activated when the bypass voltage or frequency is abnormal.
6	BATTERY ABNORMAL	Activated when the battery is abnormal.
7	BATTERY LOW VOL.1	Activated when the battery voltage drops below Discharge Warning Voltage Level 1 during inverter operation. This level is set in the TEST MENU by an Authorized Toshiba Service Provider.
8 *	BATTERY LOW VOL.2	Activated when the battery voltage drops below Discharge Warning Voltage Level 2 during inverter operation. This level is set in the TEST MENU by an Authorized Toshiba Service Provider. <i>This is the default setting for OUT5.</i>
9	BATTERY DEPLETION	Activated when the battery voltage drops below discharge end voltage level during inverter operation.
10 *	OVERLOAD	Activated when an overload of 105% or more had occurred to the system. <i>This is the default setting on OUT6.</i>
11	OVERLOAD PREALARM	Activated when the load goes over 100%. This level is adjustable by an Authorized Toshiba Service Provider.
12	FAULT GROUP 1	Activated when the preset group of alarms (Fault Group 1) all occur to the system at once. These groups are set in the TEST MENU by an Authorized Toshiba Service Provider.

Code	Function	Description
13	FAULT GROUP 2	Activated when the preset group of alarms (Fault Group 2) all occur to the system at once. These groups are set in the TEST MENU by an Authorized Toshiba Service Provider.
14	BYPS.SYNCHRONOUS	Activated when the inverter voltage and bypass voltage are synchronous.
15	BYPS.ASYNCHRONOUS	Activated when the inverter voltage and bypass voltage are asynchronous.
16	REMOTE OPE.ENABLE	Activated when any remote operation occurs (Stop/Start Inverter, etc.)
17 *	LOAD ON INVERTER	Activated when the power is supplied from the inverter. <i>This is the default setting on OUT2.</i>
18 *	LOAD ON BYASS	Activated when the power is supplied from the inverter. <i>This is the default setting on OUT1.</i>
19	LOAD ON AC	Activated when the power is supplied from the input via the UPS's rectifier/converter - inverter.
20 *	BATTERY OPERATION	Activated when the battery is operating following an AC power failure. <i>This is the default setting on OUT3.</i>
21 *	CONVERTER OPERATION	Activated when the converter is operating. <i>This is the default setting on OUT4</i>
22	INVERTER OPERATION	Activated when the inverter is operating.
23	CB1 CLOSE	Activated when CB1 (Input Contactor) is closed.
24	CB2 CLOSE	Activated when CB2 (Battery Breaker) is closed.
25	52S CLOSE	Activated when 52S (Bypass Contactor) is closed.
26	POWER DEMAND ON	Activated when a Power Demand is activated by one of the Inputs.
27	EQUALIZING CHARGE	Activated when the UPS is charging the batteries at the equalizing charge level. This command boosts the charge voltage (500-640 V) for a preset duration (0-100 hr.)
28	ANOTHER BUS SYNC.OK	Annunciates that the UPS is successfully synchronized to an external source

*Default output settings

5 INSTALLATION AND OPERATION

5.1 TRANSPORTATION AND INSTALLATION

Transport with forklift. If carry by overhead crane, use four eyebolts (Not provided)

Table 5–1 Transport by Overhead Crane

Model	UPS Cabinet	Landing Cabinet *
100 kVA	4 x M12 Lifting Eyes	N/A
160 kVA	4 x M12 Lifting Eyes	N/A
225 kVA	4 x M12 Lifting Eyes	N/A
300 kVA	4 x M20 Lifting Eyes	4 x M12 Lifting Eyes
500 kVA	4 x M20 Lifting Eyes	4 x M12 Lifting Eyes
650 kVA	4 x M24 Lifting Eyes	4 x M12 Lifting Eyes
750 kVA	4 x M24 Lifting Eyes	4 x M12 Lifting Eyes

* Use lifting eyes on landing cabinet only to lift landing cabinet by itself, not as part of assembled unit.

Install the unit using the four pre-drilled holes in the UPS channel base. Anchor the unit using appropriate hardware. (Not provided).



Do not transport UPS cabinet laid horizontally.

PROHIBIT



Cabinets must be maintained upright within $\pm 15^\circ$ of the vertical during handling.

NOTE

5.2 INSTALLATION PROCEDURE

A) Note the load tolerance of the floor

Refer to Table 5–2 for list of UPS weights.

Table 5–2 List of UPS Weights

UPS Capacity (kVA)	100	160	225	300	500	650	750
Weight (lbs.)	855	1160	1230	2260	3360	4250	4250

B) Minimum clearance required for ventilation

Right side 1 in. (25 mm) (not required when sidecars are used)

Left side 1 in. (25 mm) (not required when sidecars are used)

Back side 0.0 in. (0 mm)

Top side (100-225kVA) 20 in. (500 mm) (for air flow)

Top side (300-750kVA) 23.6 in. (600 mm) (for air flow)

C) Space requirement for routine maintenance

Allow for the following space at the time of installation.

Front (100-225kVA)	40 in. (1000 mm)
Front (300-750kVA)	42.3 in. (1075 mm)
Sides	0.0 in. (0 mm)
Back side	0.0 in. (0 mm)
Top side	20 in. (50 mm)

D) External Battery Supply

Please refer to the following when installing and maintaining batteries:



NOTE

1. The customer shall refer to the battery manufacturer's installation manual for battery installation and maintenance instructions.
2. The maximum permitted fault current from the remote battery supply and the DC voltage rating of the battery supply over-current protective device are shown in Table 5-3.

Table 5-3 Maximum Recommended Fault Current

UPS Capacity (kVA)	DC Voltage Rating (V)	Maximum Recommended Fault Current (A)
100	480	25,000
160	480	25,000
225	480	25,000
300	480	25,000
500	480	25,000
650	480	25,000
750	480	25,000

5.3 PROCEDURE FOR CABLE CONNECTIONS

1. Confirm the capacity of the UPS being installed. Identify the input/output power Terminal blocks accordingly as shown in the Figure 5-1 thru Figure 5-11.
2. Connect the internal control wire and power wire.
 - (1) Control wire Inter-connect
 1. CB2 UVR to terminal TN1-1, 2 of external I/F PCB IOAU-09.
 2. CB2 ON Auxiliary to terminal TN1-3, 4 of external I/F PCB IOAU-09.
 - (2) Power wire (AC input, Bypass input, AC output) Inter-connect
 - a.) From user's distribution panel
 1. X1 (A-phase) to A bus bar in UPS
 2. X2 (B-phase) to B bus bar in UPS
 3. X3 (C-phase) to C bus bar in UPS
 - b.) DC Input to UPS
 1. Positive cable to BP bus bar in UPS
 2. Negative cable to BN bus bar in UPS



NOTE

After the completion of the input power cables connection:

With a phase rotation meter, check that the phase rotation of the AC Input power terminals A, B and C as well as the Bypass Input power terminals A40, B40 and C40 are correct. The proper phase rotation is clockwise A(R) → B(S) → C(T).

3. Connect the grounding conductor from the input service entrance to the UPS Ground Bar (E).



REQUIRED

4. Two (2) sources feeding the UPS:

- (1) Connect the AC input power cables from the input service entrance to the AC input power terminals, identified as A, B, C in Figure 5-1 thru Figure 5-8. Input cables must be sized for an ampere rating larger than the maximum input drawn by the converter. (Refer to equipment nameplate for current ratings.) Confirm that an external bypass input circuit breaker (MCCB) is installed (refer to WARNING 4, page 5). Connect the bypass input power cables from the input service entrance to the bypass input power terminals, identified as A40, B40 and C40 in Figure 5-1 thru Figure 5-8. Bypass input cables must be sized for an ampere rating larger than the maximum output current capacity of the UPS. Refer to Table 5–4 for recommended cable sizes.
- (2) Connect the external signal terminal block as desired. Refer to Section 4.4 and Figure 4-19 for functional description. 14 AWG (2mm²), or less, shielded conductor is recommended.

5. One (1) source feeding the UPS:

- (1) Confirm that an external input circuit breaker sized to protect both the AC input and the bypass line is installed. (Refer to equipment nameplate for current ratings.) Connect the bypass input power cables from the input service entrance to the bypass input power terminals, identified as A40, B40 and C40 in Figure 5-1 thru Figure 5-8. Input cables must be sized for an ampere rating larger than the maximum current capacity of the UPS. Refer to Table 5–4 for recommended cable sizes.
- (2) Using adequately sized conductors and referring to the appropriate figure identified in Figure 5-1 thru Figure 5-8, connect jumper bypass terminals A40, B40, C40 to AC input power terminals A, B, C as identified in Figure 5-1 thru Figure 5-8.

- (3) Connect the external signal terminal block as desired. Refer to Section 2.4 and Figure 2.10 for functional description. 14 AWG (2mm²), or less, shielded conductor is recommended.



NOTE

1. *Confirm that all UPS internal contactors (breakers) "CB1", "CB2", and "CB3" are open before energizing UPS.*
2. *UPS power terminals are supplied with stud type fittings.
It is recommended that compression lugs be used to fasten all input/output power cables.*

6. Procedure for Cable Connections for Parallel Operation System

- (1) Confirm the number of units to be connected in parallel. Identify the input/output power terminal blocks and control wire connections for parallel operation systems as shown in the appropriate Figure 5-1 thru Figure 5-8.
- (2) Connect the external control wire and power wire.



NOTE

Straight through, shielded CAT5 cables with metal shrouded RJ-45 plugs on both sides are to be used for the parallel control signal cables. Use of any other cables could cause erroneous communication failures.

a.) Control wire connection

Parallel configuration wiring (Refer to Figure 5-13 to Figure 5-20)

- 52L control signal from Toshiba Tie Cabinet (TTC) to UPS-n IOAU-09 (TN1– 5, 6).

a.1) 100-225kVA

- Parallel control signal for CN94 as shown in Figure 5-14.
- Parallel control signal for CN96 and CN95 as shown in Figure 5-14.

a.2) 300-750kVA

- Parallel control signal for CN941, CN942, CN943, CN944, CN951, CN952, CN953, CN954 as shown in Figure 5-15 to Figure 5-20.
- Parallel control signal for CN96, CN97, CN98 and CN99 as shown in Fig. 3.7.2 – 4.

b.) Power wire connection

From UPS AC Output Terminals to Toshiba Tie Cabinet (TTC) (Refer to Figure 5-1 thru Figure 5-8)

Table 5-4 Recommended Cable Sizes

kVA Capacity	Input Voltage	Output Voltage	Input Side		Output Side		Bypass Side		DC Input Side	
			Cable Size	Torque ft. lbs.	Cable Size	Torque ft. lbs.	Cable Size	Torque ft. lbs.	Cable Size	Torque ft. lbs.
100kVA	480V	480V	2/0 AWG – 3/0 AWG	17-22 ft. lbs.	2/0 AWG – 3/0 AWG	17-22 ft. lbs.	2/0 AWG – 3/0 AWG	17-22 ft. lbs.	250 MCM – 300 MCM	17-22 ft. lbs.
160kVA	480V	480V	250 MCM – 300 MCM	17-22 ft. lbs.	250 MCM – 300 MCM	17-22 ft. lbs.	250 MCM – 300 MCM	17-22 ft. lbs.	(2) x 3/0 AWG – (2) x 250 MCM	17-22 ft. lbs.
225kVA	480V	480V	500 MCM – (2) x 250 MCM	17-22 ft. lbs.	500 MCM – (2) x 250 MCM	17-22 ft. lbs.	500 MCM – (2) x 250 MCM	17-22 ft. lbs.	(2) x 350 MCM – (2) x 400 MCM	17-22 ft. lbs.
300kVA	480V	480V	(2) x 250 MCM – (2) x 300 MCM	29-39 ft. lbs.	(2) x 250 MCM – (2) x 300 MCM	29-39 ft. lbs.	(2) x 250 MCM – (2) x 300 MCM	29-39 ft. lbs.	(3) x 300 MCM – (3) x 350 MCM	29-39 ft. lbs.
500kVA	480V	480V	(3) x 300 MCM – (3) x 350 MCM	29-39 ft. lbs.	(3) x 300 MCM – (3) x 350 MCM	29-39 ft. lbs.	(3) x 300 MCM – (3) x 350 MCM	29-39 ft. lbs.	(4) x 500 MCM – (5) x 300 MCM	29-39 ft. lbs.
650kVA	480V	480V	(4) x 350 MCM – (4) x 400 MCM	29-39 ft. lbs.	(3) x 400 MCM – (4) x 250 MCM	29-39 ft. lbs.	(3) x 400 MCM – (4) x 250 MCM	29-39 ft. lbs.	(5) x 400 MCM – (5) x 500 MCM	29-39 ft. lbs.
750kVA	480V	480V	(4) x 350 MCM – (5) x 250 MCM	29-39 ft. lbs.	(4) x 350 MCM – (5) x 250 MCM	29-39 ft. lbs.	(4) x 350 MCM – (5) x 250 MCM	29-39 ft. lbs.	(6) x 400 MCM – (6) x 500 MCM	29-39 ft. lbs.

*1 – The cables must be selected to be equal to the sizes listed in the table.

*2 – Voltage drop across power cables not to exceed 2% of nominal source voltage.

*3 – Allowable ampere-capacities based on 75 °C insulated copper conductor at ambient temperature of 30 °C.

*4 – All wiring to be in accordance with all applicable national and/or local electrical codes.

Table 5-5 Crimp Type Compression Lug

WIRE SIZE (CODE)	WIRE STRAND CLASS	RECOMMENDATION		CRIMP TOOL REQUIRED BURNDY TYPE Y35 OR Y46	
		VENDOR	CAT. NO.	COLOR KEY	DIE INDEX
1 AWG	B	BURNDY	YA1C	GREEN	11 / 375
	I	ILSCO	CRA-1L	GREEN	11 / 375
		BURNDY	YA25-LB	---	1019
1/0 AWG	B	BURNDY	YA25	PINK	12 / 348
	I	ILSCO	CRA-1/OL	PINK	12 / 348
		BURNDY	YA25-LB	---	1020
2/0 AWG	B	BURNDY	YA26	BLACK	13
	I	ILSCO	CRA-2/OL	BLACK	13
		BURNDY	YA27-LB	---	1021
3/0 AWG	B	BURNDY	YA27	ORANGE	14 / 101
	I	ILSCO	CRB-3/OL	ORANGE	14 / 101
		BURNDY	YA28-LB	---	1022
4/0 AWG	B	BURNDY	YA28	PURPLE	15
	I	ILSCO	CRB-4/OL	PURPLE	15
		BURNDY	YA29-LB	---	1023
250 MCM	B	BURNDY	YA29	YELLOW	16
	I	ILSCO	CRA-250L	YELLOW	16
		BURNDY	YA30-LB	---	1024
300 MCM	B	BURNDY	YA30	WHITE	17 / 298
	I	ILSCO	CRA-300L	WHITE	17 / 298
		BURNDY	YA32-LB	---	1026
350 MCM	B	BURNDY	YA31	RED	18 / 324
	I	ILSCO	CRA-350L	RED	18 / 324
		BURNDY	YA34-LB	---	1027
400 MCM	B	BURNDY	YA32	BLUE	19 / 470
	I	ILSCO	CRA-400L	BLUE	19 / 470
		BURNDY	YA36-LB	---	1027
500 MCM	B	BURNDY	YA34	BROWN	20 / 299
	I	ILSCO	CRA-500L	BROWN	20 / 299
		BURNDY	YA38-LB	---	1029

NOTE: When using crimp type lugs, the lugs should be crimped to the specifications given in the manufacturer's instructions for both crimp tool and lug.

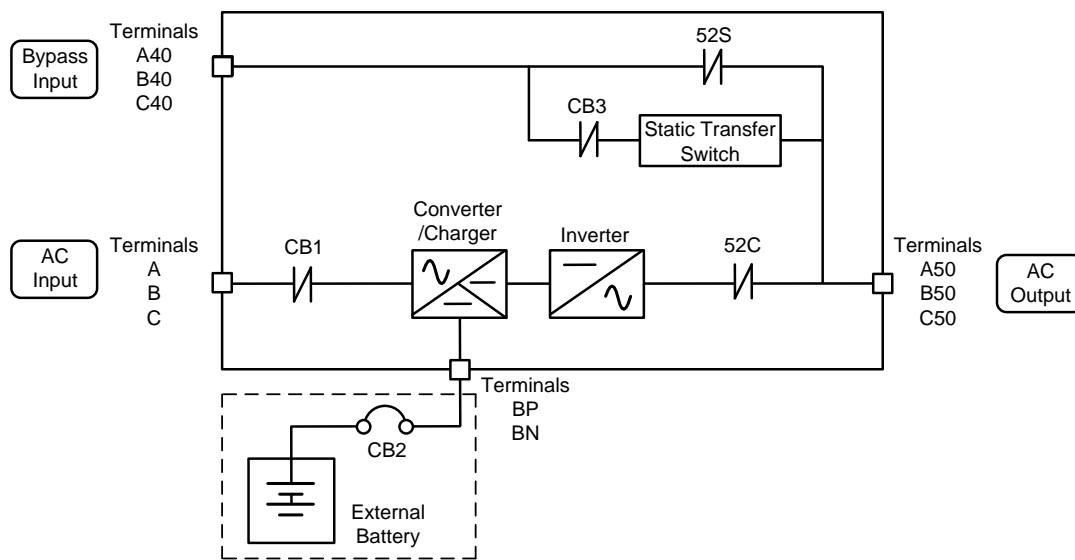

Figure 5-1 UPS Terminal Designation

Figure 5-2 Diagram of input/output bus bars and terminal blocks (100-225kVA)

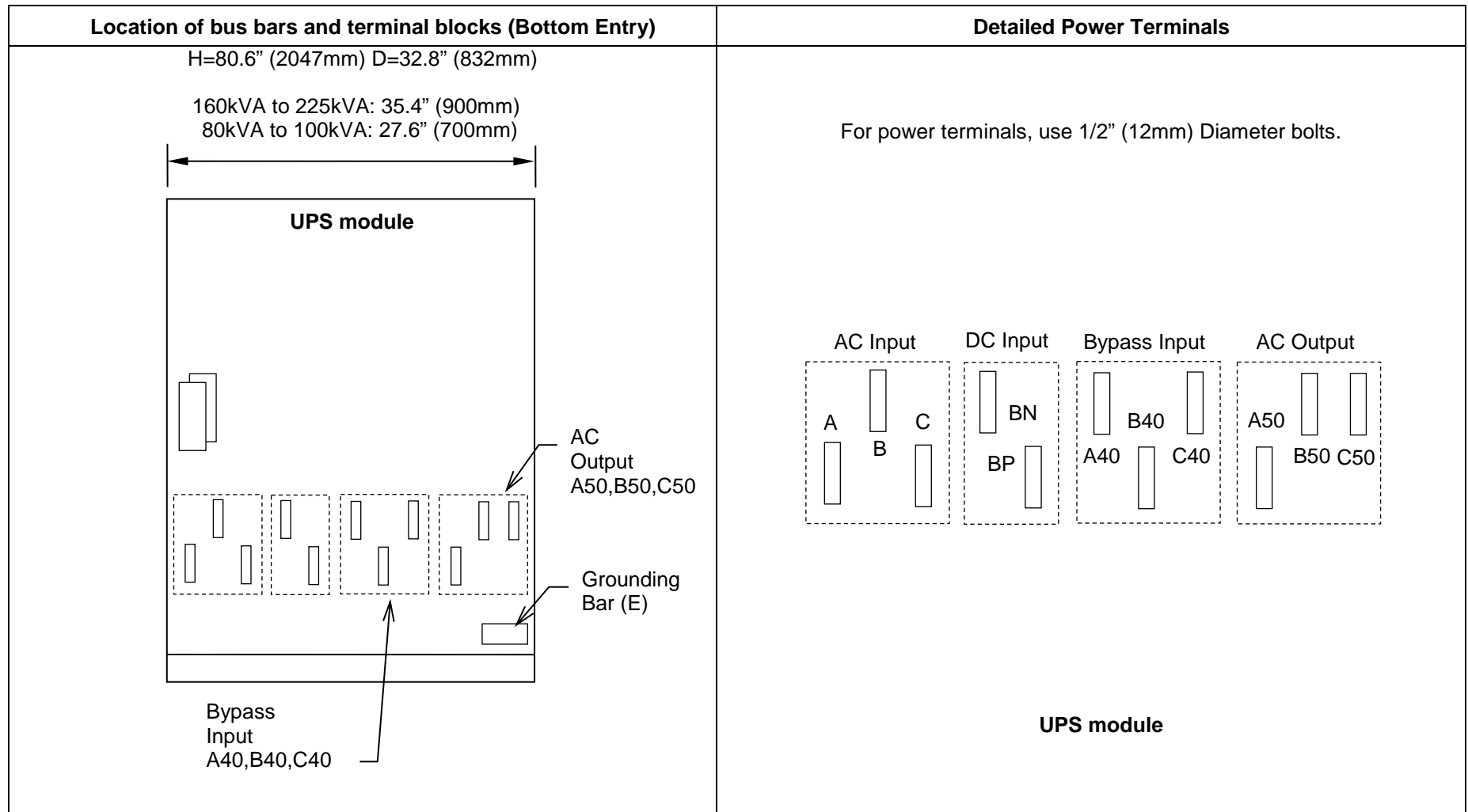

Figure 5-3 Diagram of input/output bus bars and terminal blocks (300kVA)

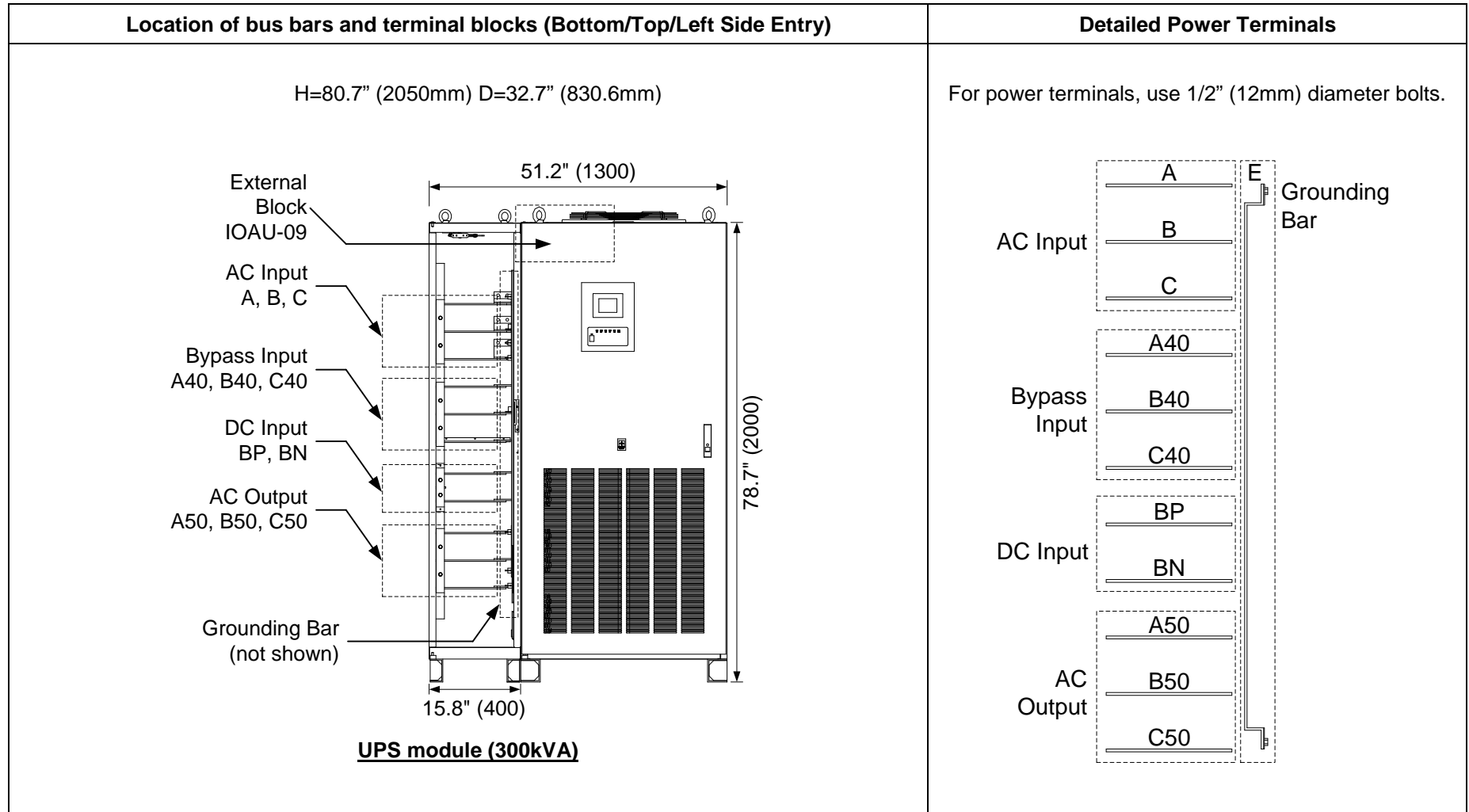

Figure 5-4 Diagram of input/output bus bars and terminal blocks (500kVA)

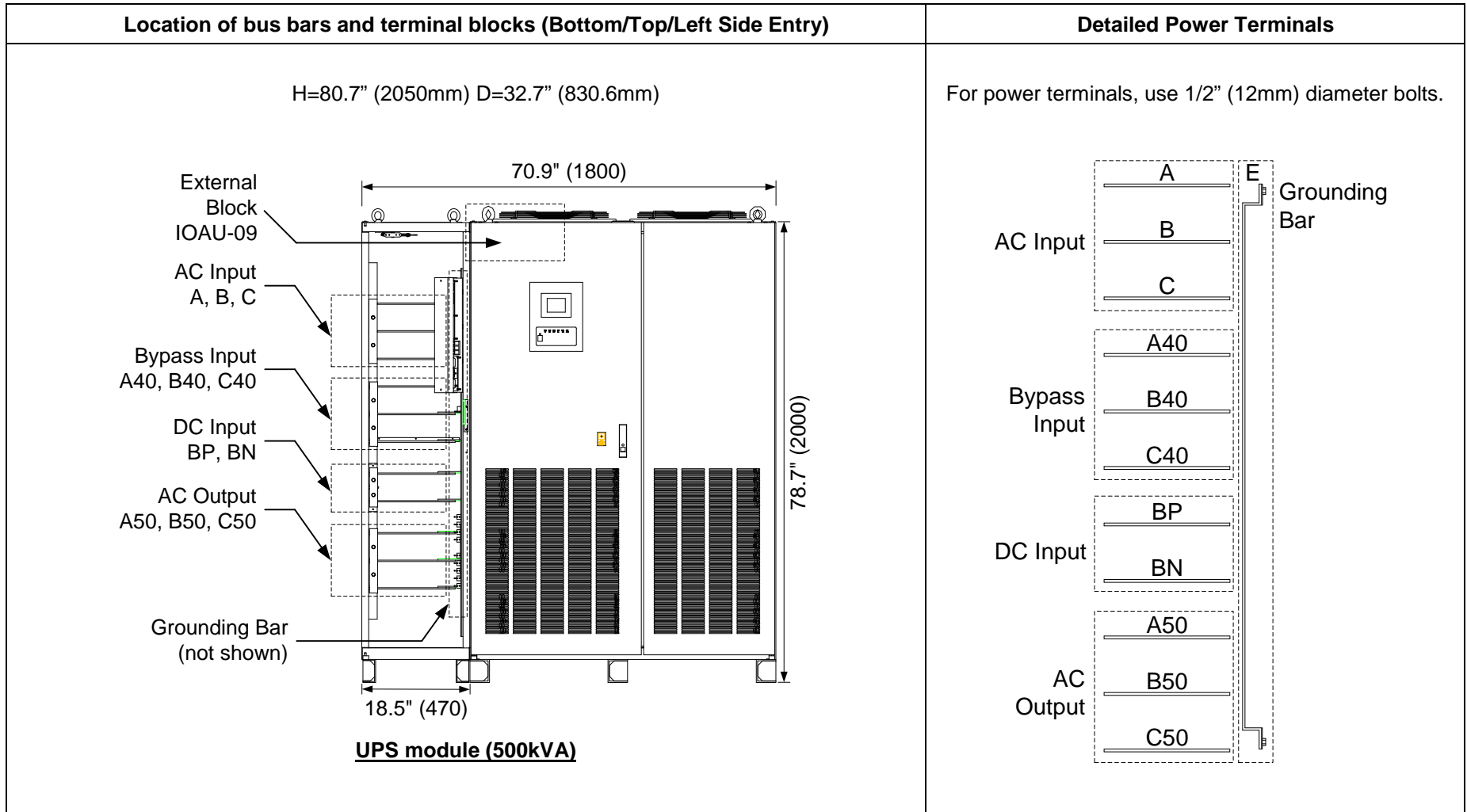

Figure 5-5 Diagram of input/output bus bars and terminal blocks (650kVA & 750kVA)

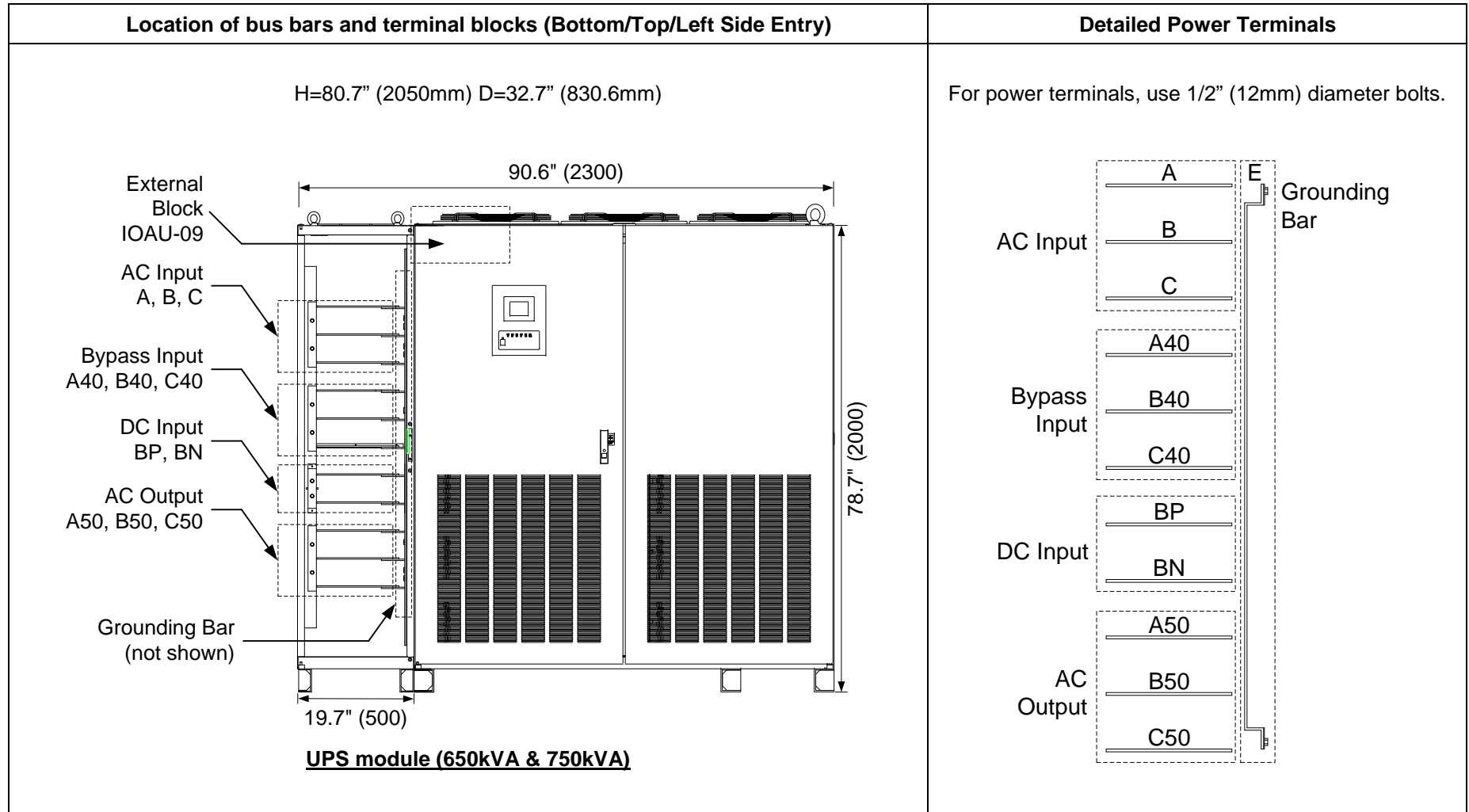

Figure 5-6 Detail of the main cabinet bus bars (300kVA)

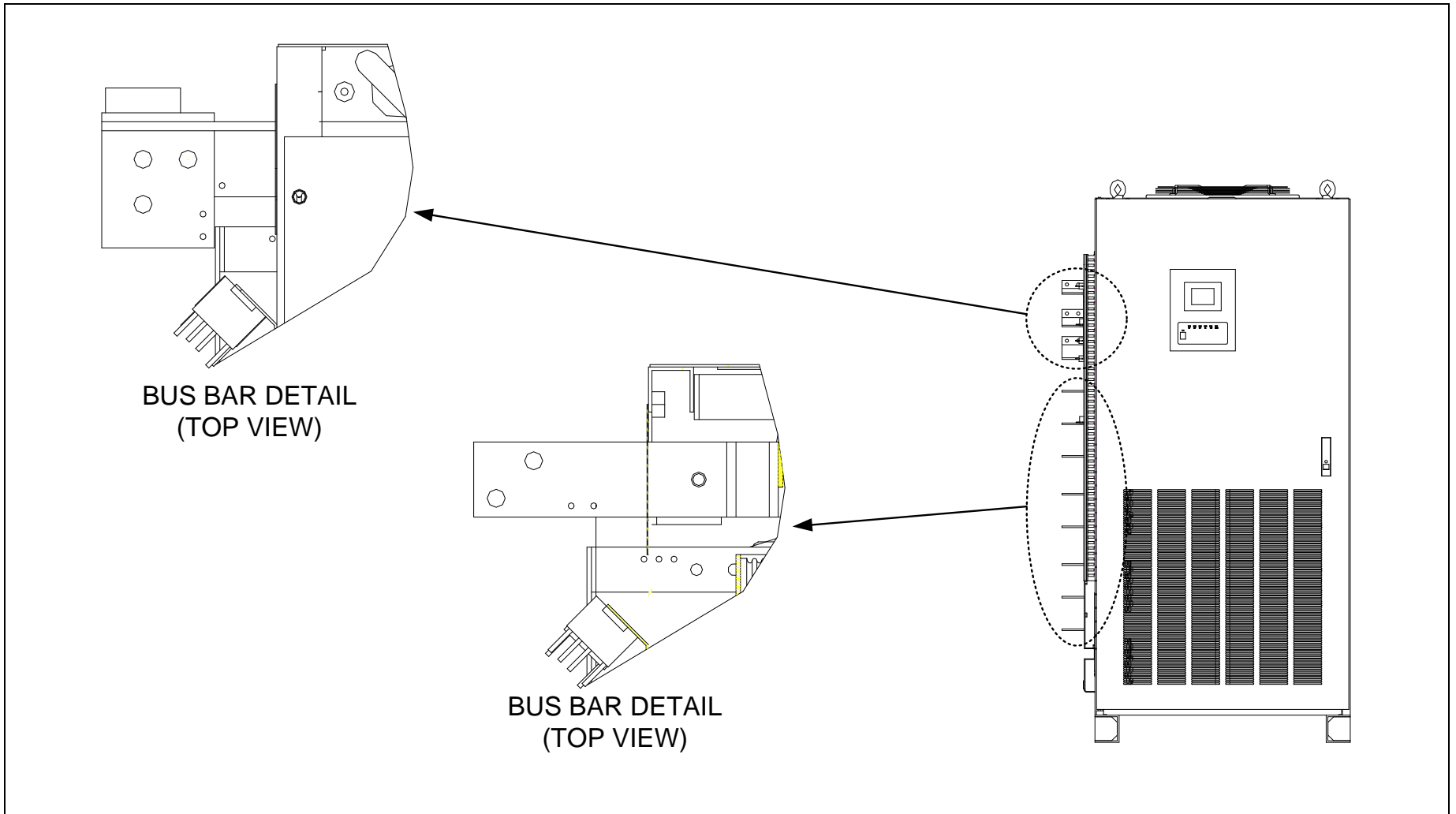

Figure 5-7 Detail of the main cabinet bus bars (500kVA)

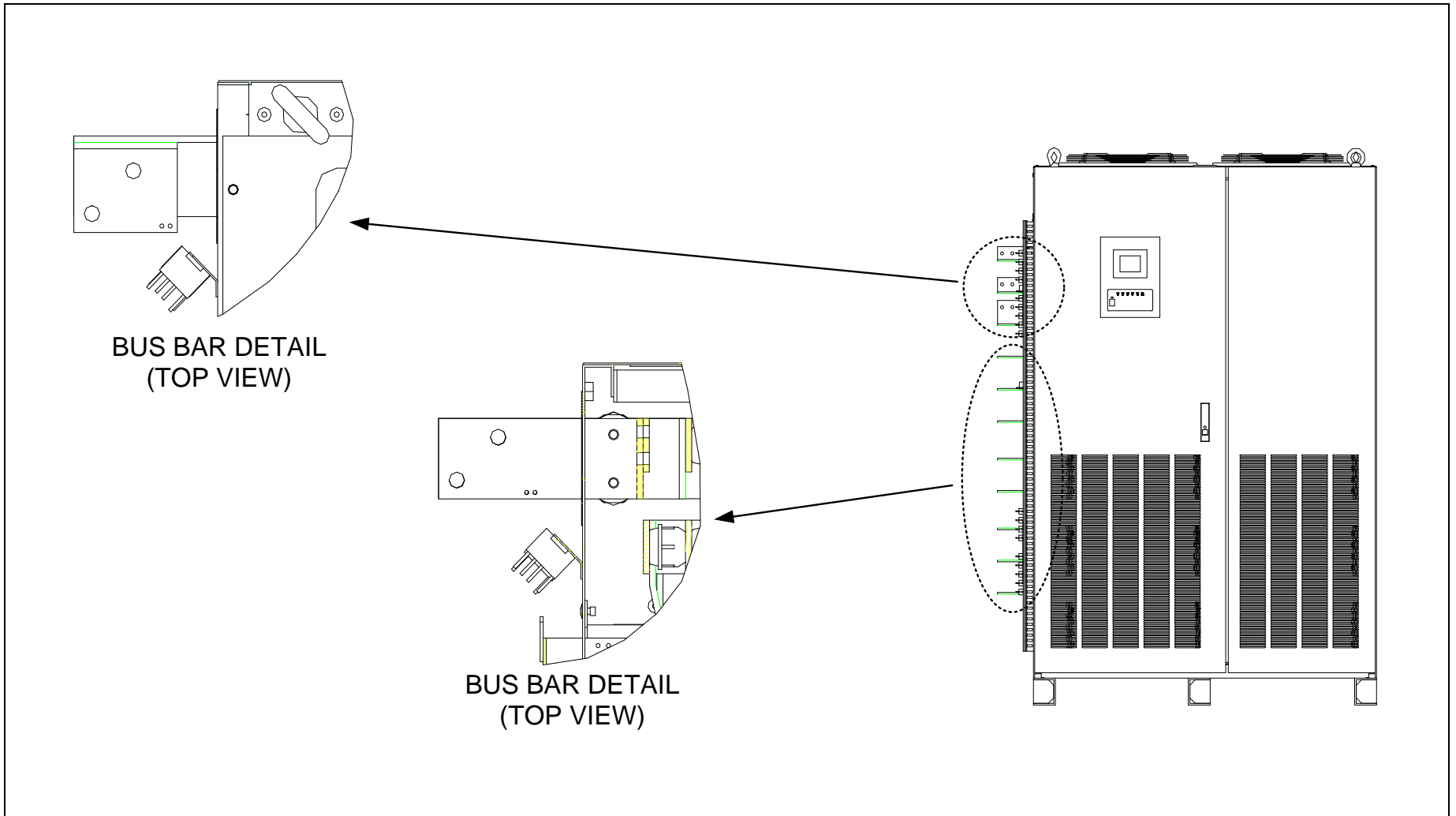

Figure 5-8 Detail of the main cabinet bus bars (650kVA & 750kVA)

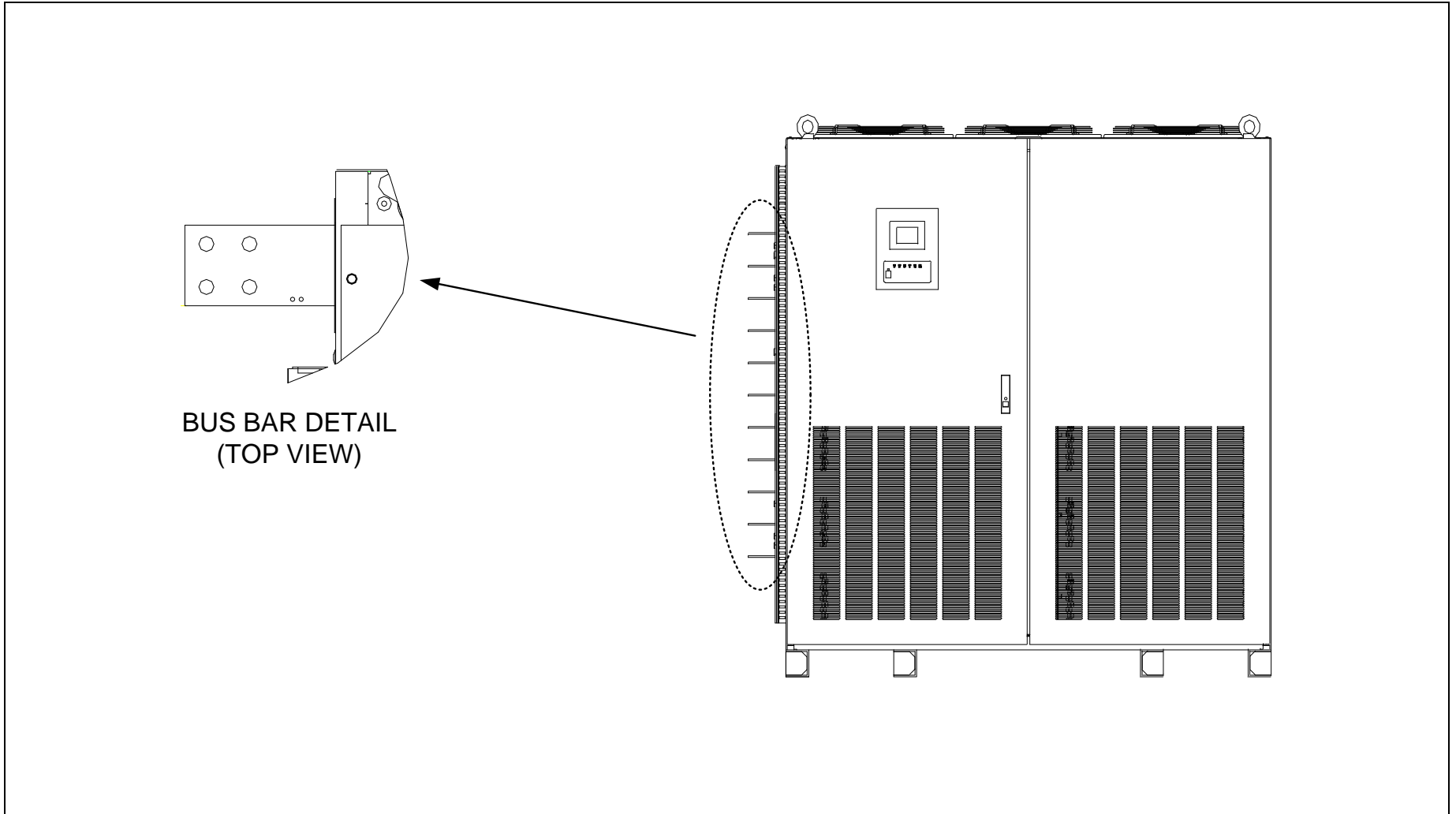

Figure 5-9 Bus bar connection between main cabinet and landing cabinet (300kVA)

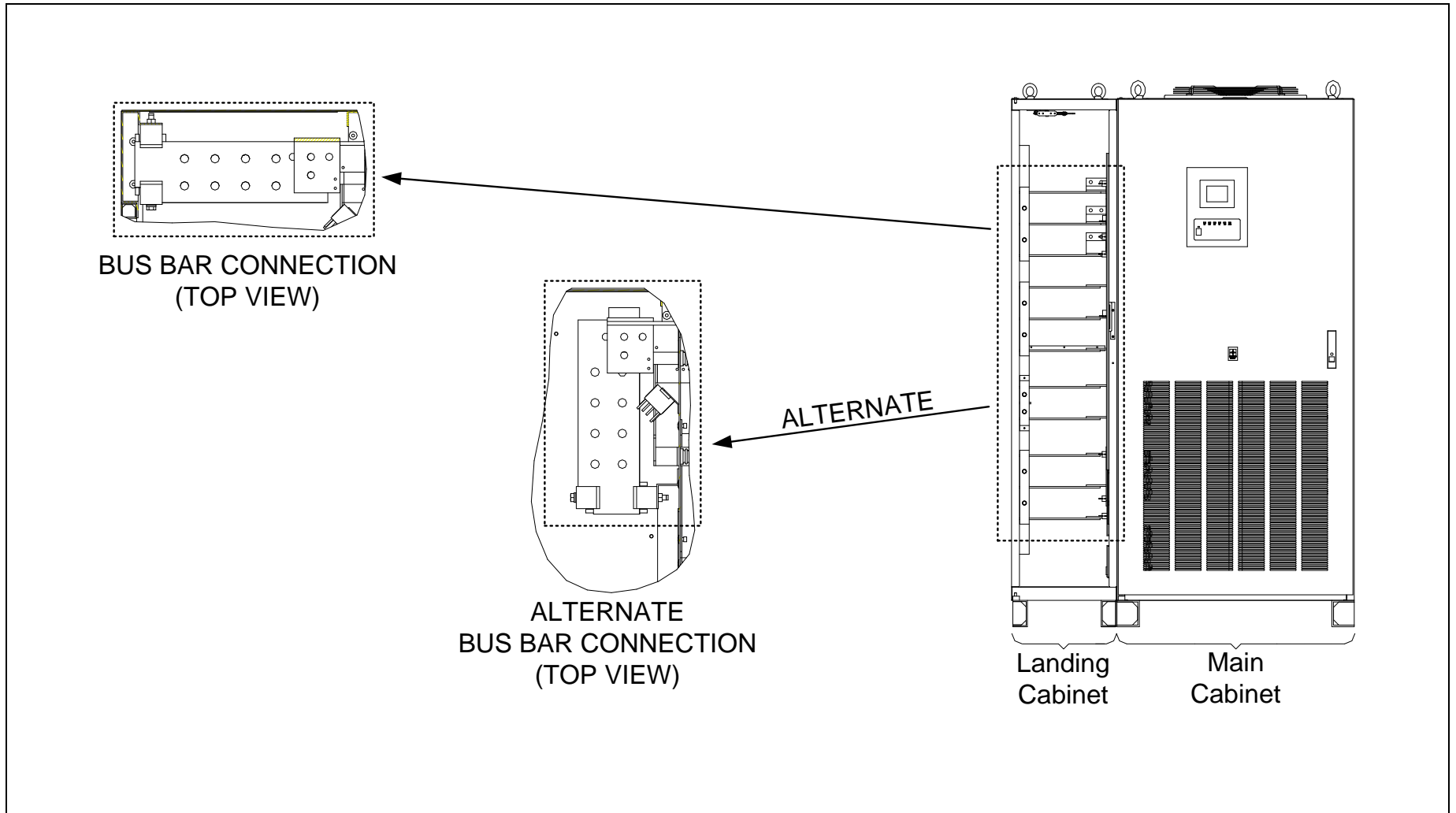

Figure 5-10 Bus bar connection between main cabinet and landing cabinet (500kVA)

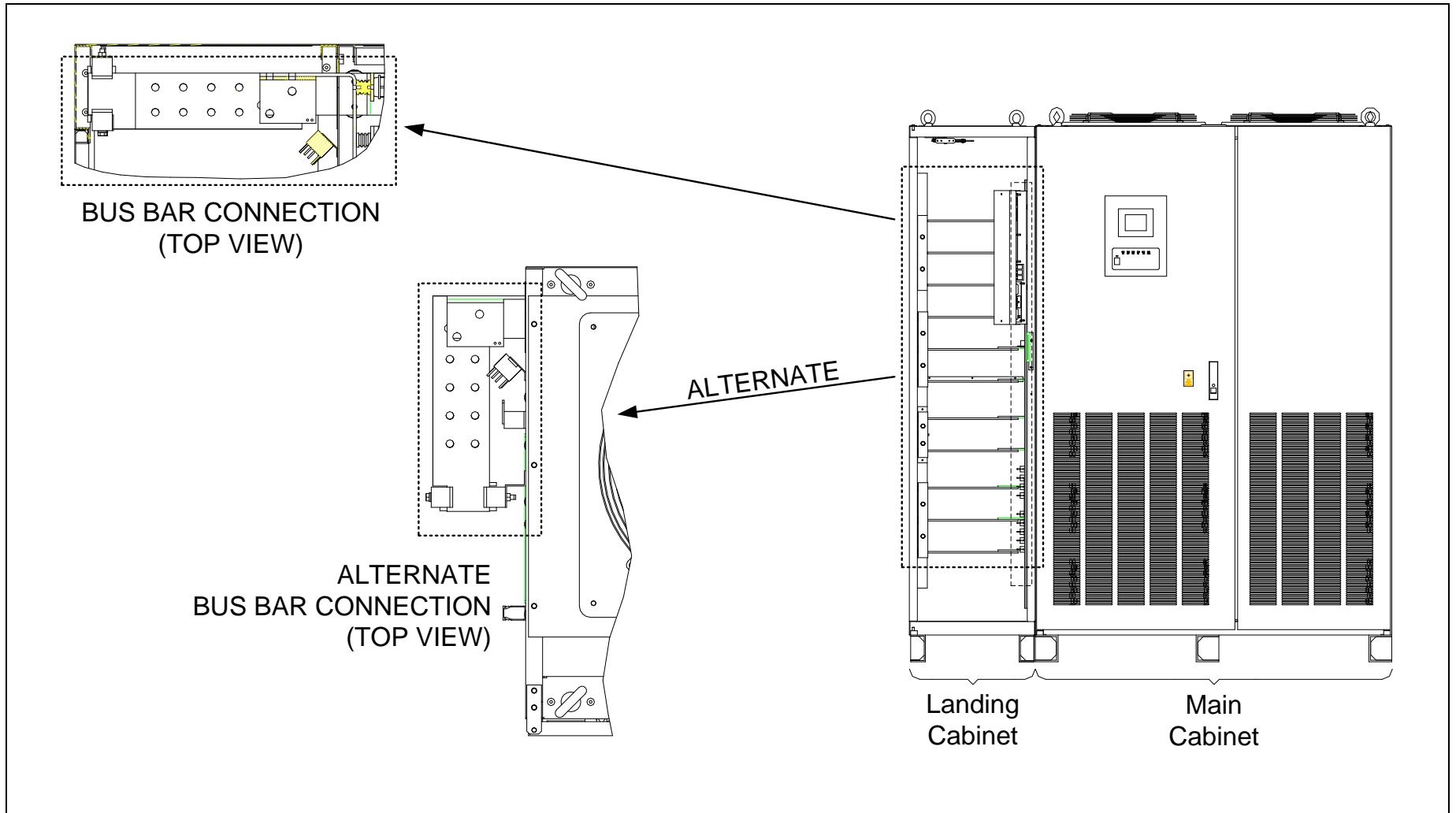

Figure 5-11 Bus bar connection between main cabinet and landing cabinet (650kVA & 750kVA)

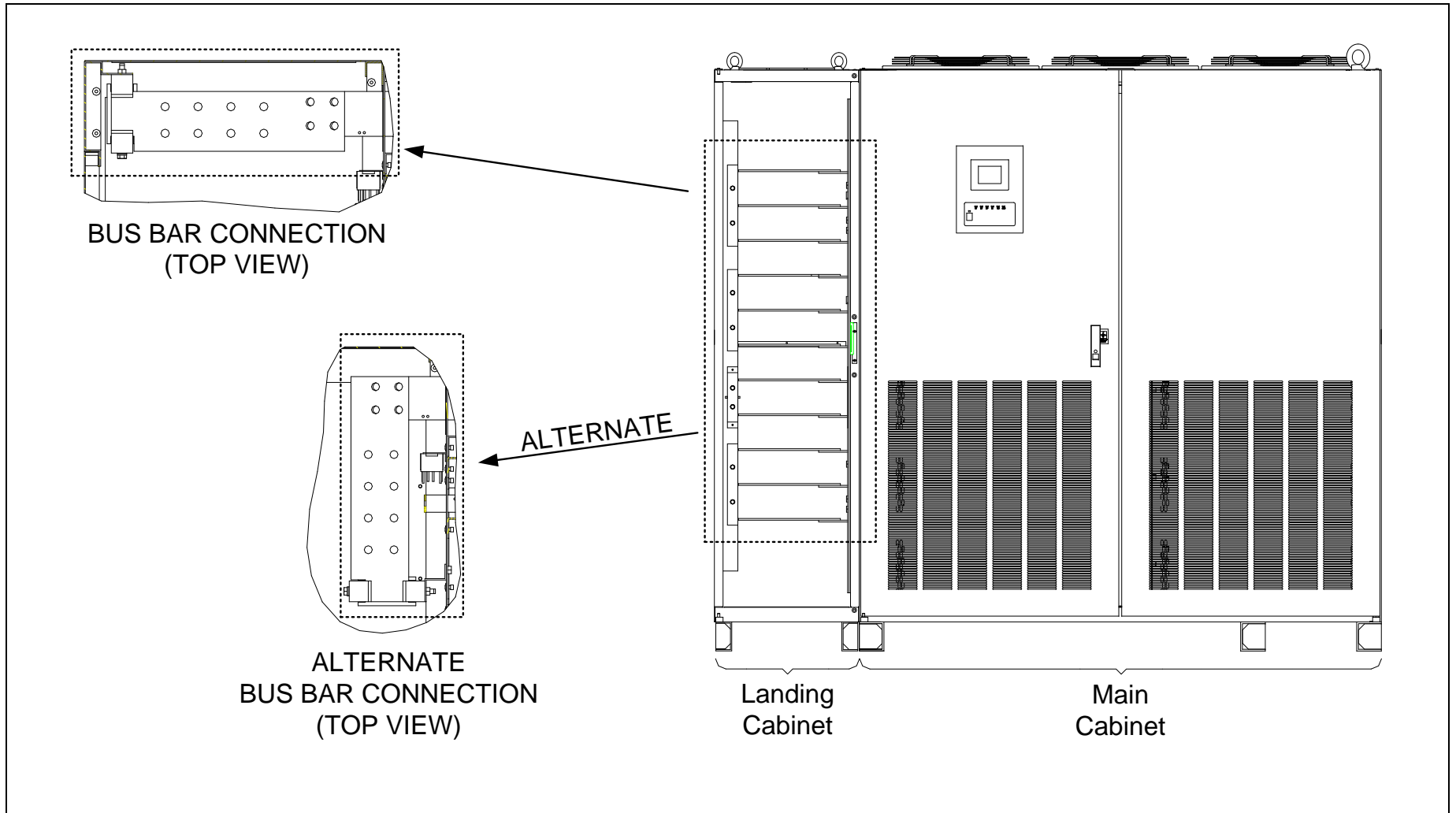

Figure 5-12 Diagram of Power Wire & Control Wire Inter-Connect between UPS and Battery

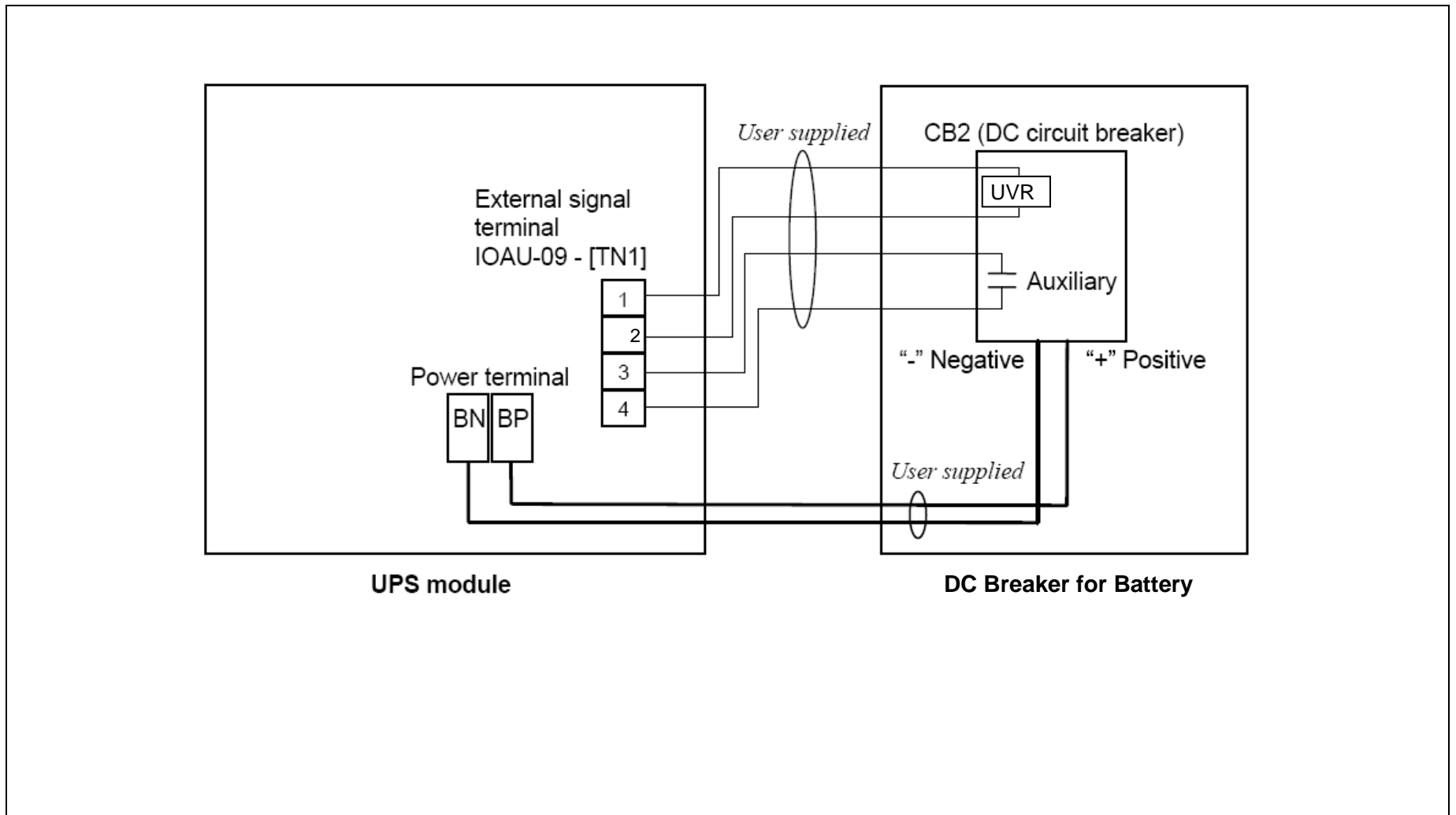

Figure 5-13 Diagram of Power Wire Connections (Parallel System Configuration)

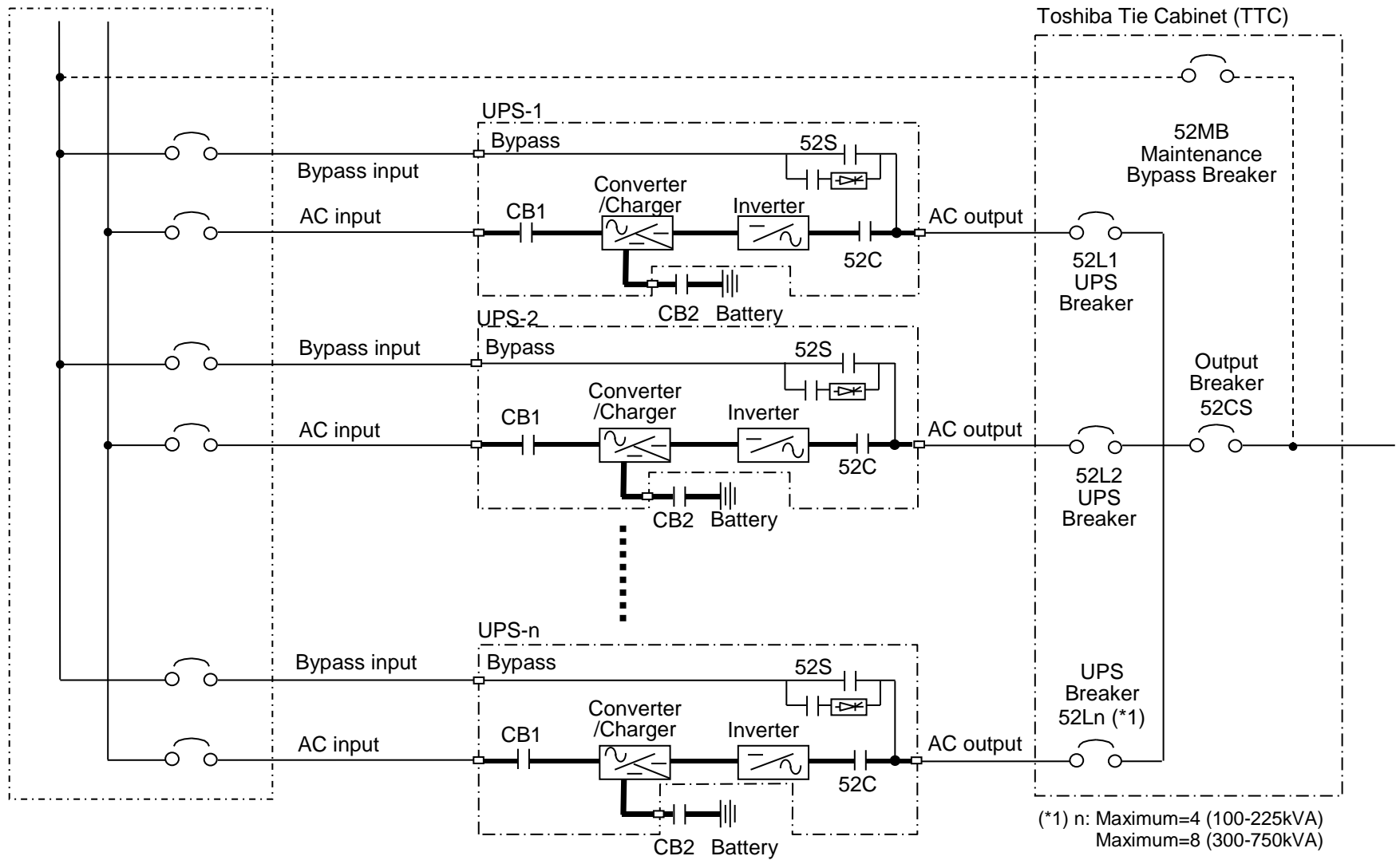

Figure 5-14 Diagram of Comm., Power, & Control Wire Connections for 4 units in MMS Config . (100-225kVA)

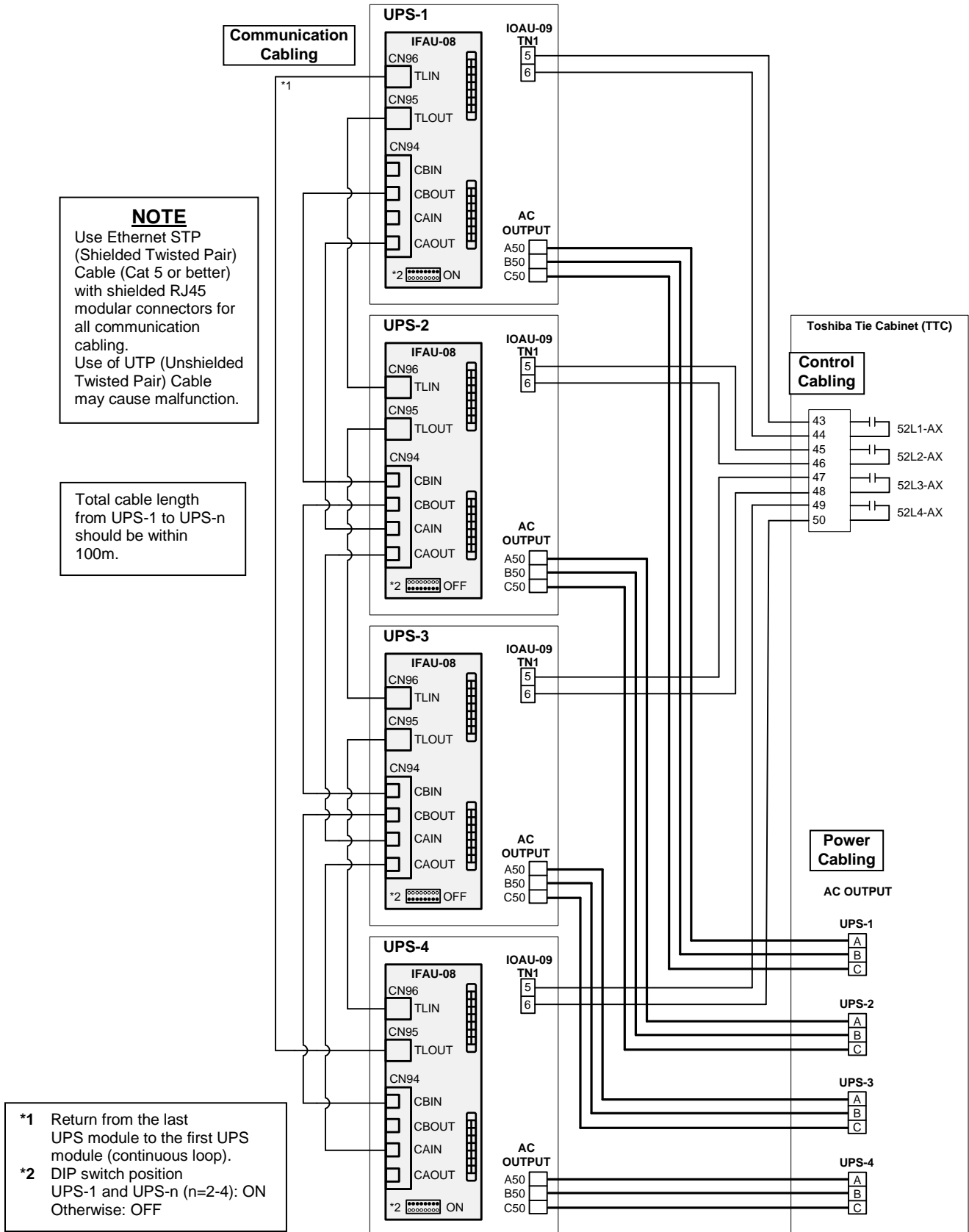

Figure 5-15 Diagram of Communication, Power & Control Wire Connections for 2 units in MMS Configuration (300-750kVA)

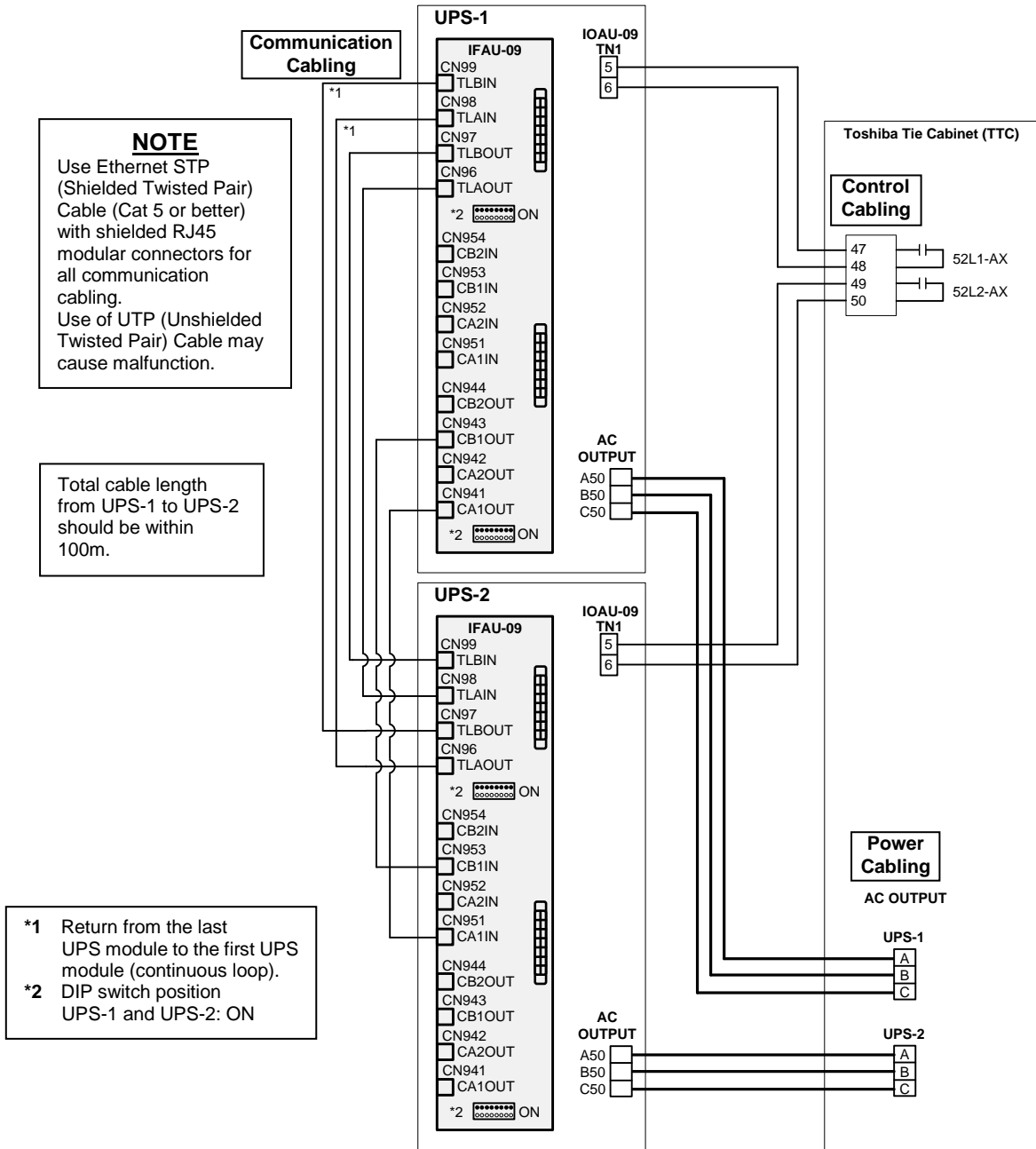

Figure 5-16 Detail of IFAU-09 Control Wire Connections for 2 units in MMS Configuration (300-750kVA)

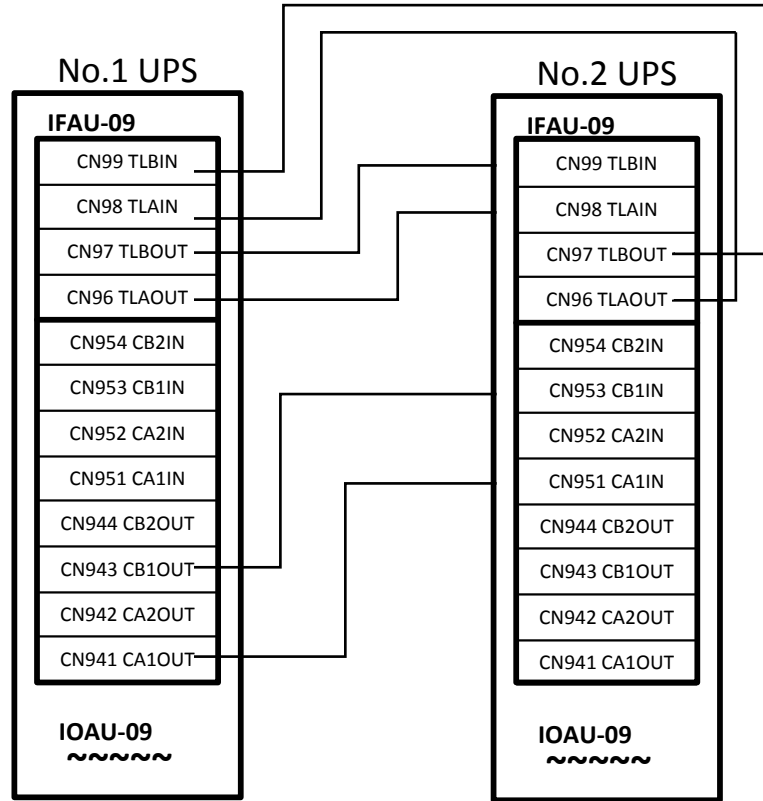

Figure 5-17 Diagram of Power Wire & Control Wire Connections for 3-4 units in MMS Config. (300-750kVA)

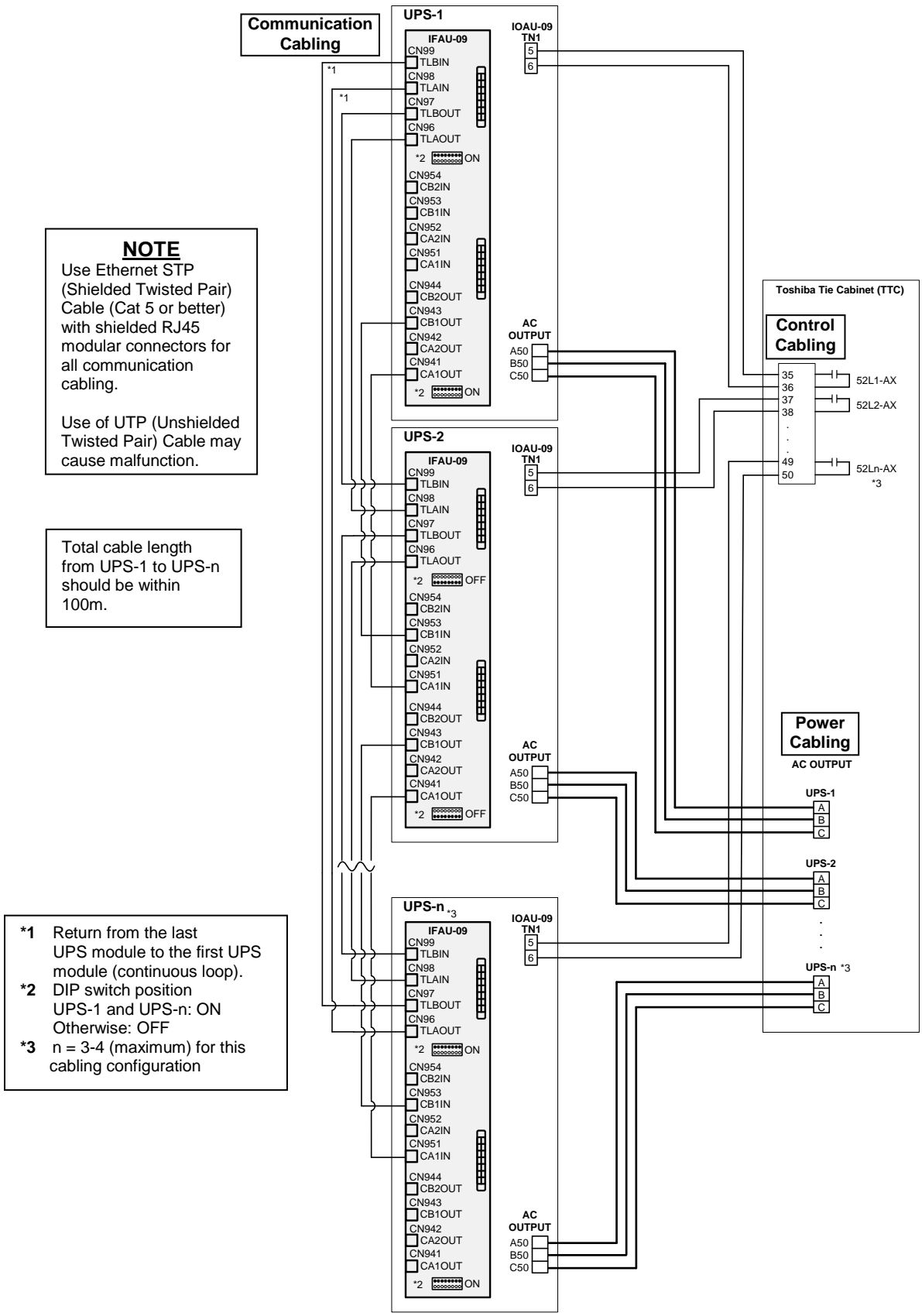

Figure 5-18 Detail of IFAU-09 Control Wire Connections for 3 or 4 units in MMS Configuration

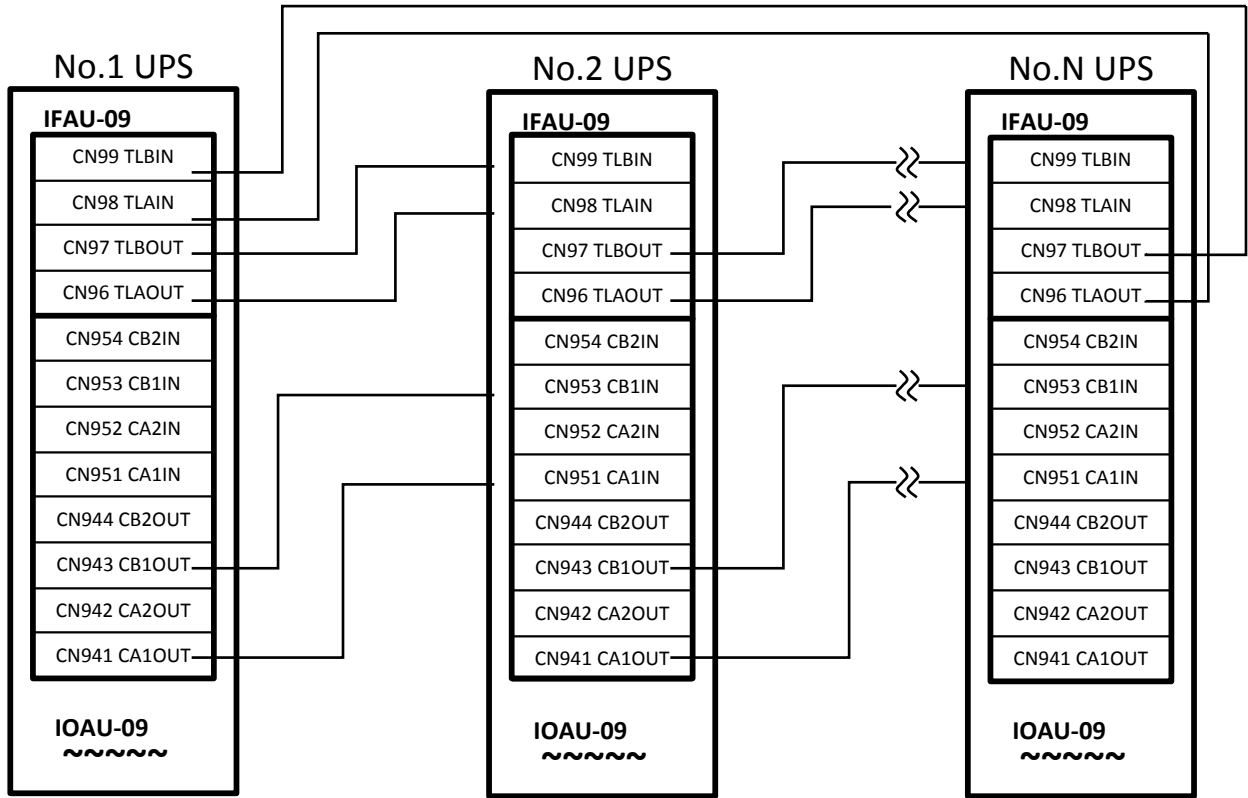

Figure 5-19 Diagram of Power Wire & Control Wire Connections for 5 to 8 units in MMS Configuration (300-750kVA)

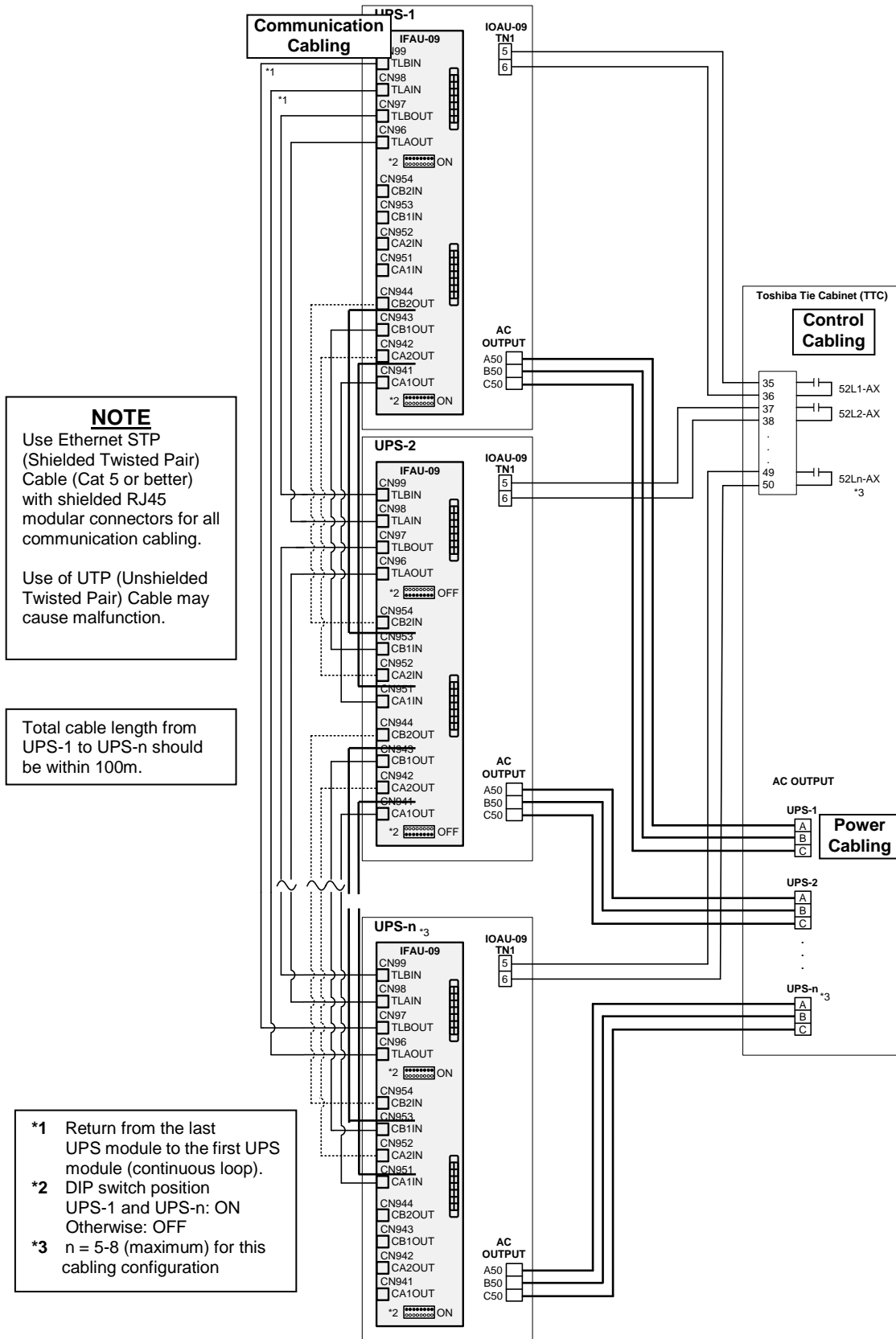
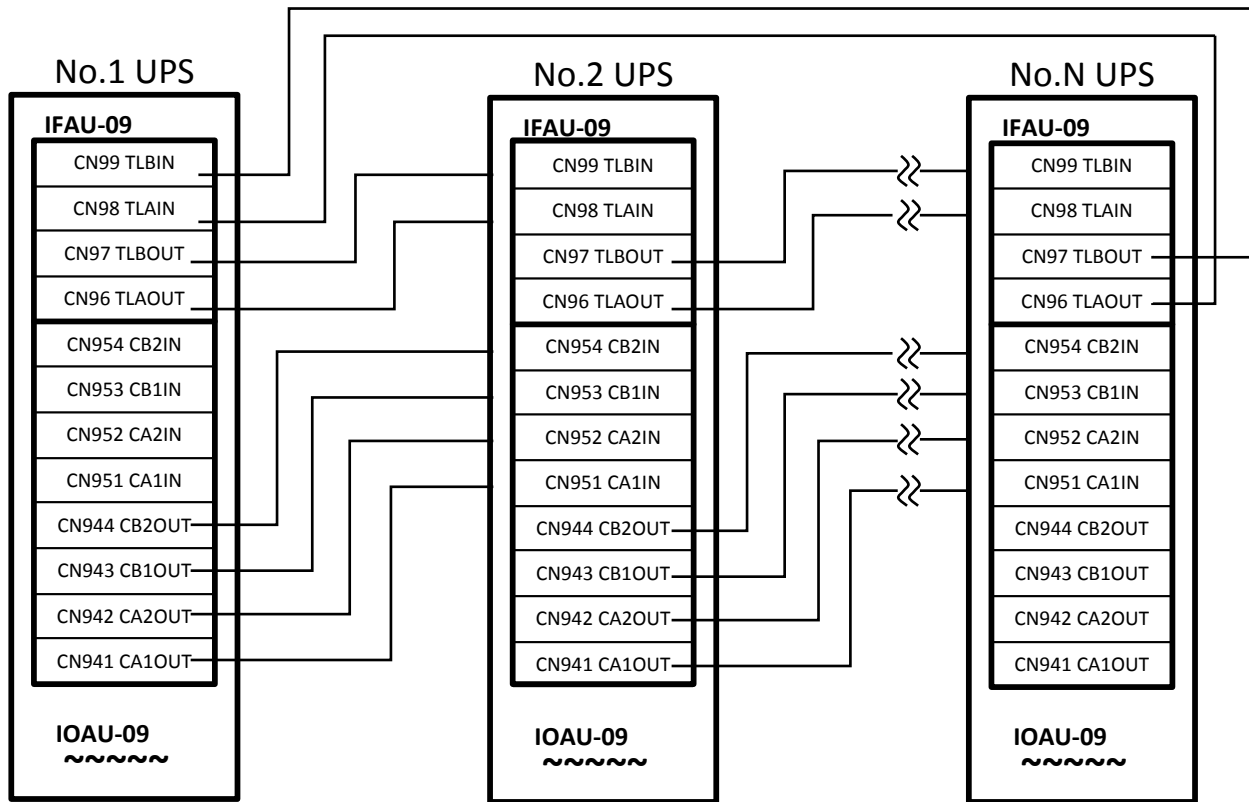

Figure 5-20 Detail of IFAU-09 Control Wire Connections for 5 to 8 units in MMS Configuration (300-750kVA)



5.4 OPERATING PROCEDURES

NOTE: To avoid inadvertently placing the UPS online or offline the START/STOP switch must be pressed and held for a period of several seconds to activate the command.

START – Press and hold the START switch for approximately 2 seconds.

STOP – Press and hold the STOP switch for approximately 5 seconds.

For Parallel Operation system, refer to section “D) MMS Start-up Procedure”.

(Parallel Operation system is herein after MMS [Multi Module System])

A) Start-up Procedure



NOTE

Before the UPS startup, the internal Bypass line starts to supply the unconditioned bypass input power to the load if the External input (or Bypass) Circuit Breaker is closed. Be extremely careful with closing the External input (or Bypass) Circuit Breaker.

Confirm the position of the circuit protectors (CPMC, CPMS and EMB) located at the upper part of the cabinet (Figure 5-21).

1) CPMC and CPMS: ON; 2) EMB: OFF.

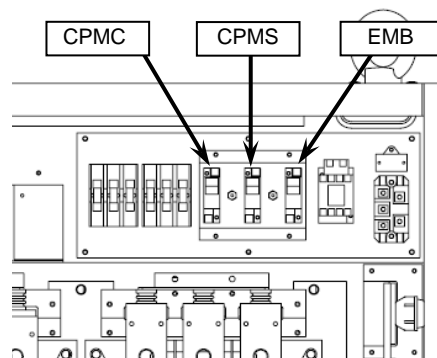

Figure 5-21 Circuit Protectors Location

- a.) Verify that the External Bypass Input Circuit Breaker for each unit is closed.
(user supplied)
- b.) Verify that Battery Disconnect Circuit Breaker (CB2) is opened or in tripping position.
- c.) If a dual source is feeding the UPS, close the External AC Input Circuit Breaker manually (user supplied).
- d.) The LCD panel boots up automatically, and the screen will show that the Load is powered by bypass line.
- e.) On the LCD panel, select “OPERATION” tab, and then press the “STARTUP GUIDANCE” button to continue UPS start-up. (Refer to Figure 2.3)
- f.) Follow the “STARTUP GUIDANCE” accordingly until the completion of the inverter startup.



NOTE

When “REMOTE OPERATION MODE” is displayed on the LCD panel, the inverter start operation can only be performed remotely. If local inverter start operation is required (at the UPS), select “LOCAL ONLY” or “REMOTE & LOCAL” in the OPERATION MENU.

B) Shut-down Procedure

If a total UPS shutdown is required, verify that the critical load is OFF.

- a.) Press the "START/STOP" icon from the Main Menu or the Operation Menu on the LCD.
- b.) On the LCD panel, press "START/STOP" icon, and then select "SHUTDOWN GUIDANCE" icon.
(Refer to Figure 2.3)
- c.) Follow the "SHUTDOWN GUIDANCE" until Inverter stops. The UPS will simultaneously transfer to Bypass operation.
- d.) In general, only the Inverter will be stopped and the Converter will remain energized to charge the batteries.



When "REMOTE OPERATION MODE" is displayed on the LCD panel, the inverter start operation can only be performed remotely. If local inverter stop operation is required (at the UPS), select "LOCAL ONLY" or "REMOTE & LOCAL" in the OPERATION MENU.

NOTE

- e.) If stopping both the Inverter and Converter is required, open the Battery Disconnect circuit breaker (CB2) manually in accordance with guidance.



CAUTION

Verify the load is OFF if the next step is to be performed.

Power to the load has been supplied through the bypass line. Power to load will be lost after execution of the next step. The load will drop.

- f.) If a dual source is feeding the UPS, open the External AC Input Circuit Breaker (user supplied) manually.
- g.) If turning off all power to the critical load is desired, open the External Bypass Input Circuit Breaker (user supplied) manually.



WARNING

In bypass mode, all UPS power terminals are still alive. Lethal voltages are present.

De-energize all external sources of AC and DC power. Before removing the covers, wait 5 minutes after de-energizing. Check no-voltage before handling UPS. Be careful of the devices even when the UPS has been de-energized, since internal devices may be energized.

C) Bypass Operation Procedure

** Transfer from Inverter to Bypass

1. Check for "SYNC" on the LCD.
2. Press the "START/STOP" icon on the LCD.
3. Follow the "SHUTDOWN GUIDANCE" and Press the "STOP" icon on the LCD.

** Transfer from bypass to inverter.

UPS

1. Press the "START/STOP" icon on the LCD.
2. Follow the "STARTUP GUIDANCE" and Press the "START" icon on the LCD.



NOTE

When "REMOTE OPERATION MODE" is displayed on the LCD panel, the inverter start operation can only be performed remotely. If local inverter start or stop operation is required (at the UPS), select "LOCAL ONLY" or "REMOTE & LOCAL" in the OPERATION MENU.

D) MMS Start-up Procedure

External Circuit Check (Ensure System is in Maintenance Bypass)

1. Verify that Tie cabinet Maintenance bypass breaker 52MB is closed.
2. Verify that Tie cabinet Output breaker 52CS is open.
3. Verify that Tie cabinet UPS breakers 52L1, 52L2...and 52Ln are closed.

Start-up from UPS-1 to UPS-n

1. Start-up each UPS in accordance with “A) Start-up Procedure”. Each UPS will start Inverter Operation synchronized with the bypass input. The Maintenance Bypass Switch is synchronized with the Static Transfer Switch.

Transfer from Maintenance Bypass to MMS Bypass Operation

1. Close Tie cabinet breaker 52CS.
2. Open Tie cabinet Breaker 52MB.



NOTE

When "REMOTE OPERATION MODE" is displayed on the LCD panel, the inverter start operation can only be performed remotely. If local inverter start operation is required (at the UPS), select "LOCAL ONLY" or "REMOTE & LOCAL" in the OPERATION MENU.

Transfer from UPS MMS Bypass Operation To UPS MMS Inverter Operation

1. Transfer MMS Bypass Operation to MMS Inverter Operation from Operation Menu on any UPS LCD as shown in Figure 5-22.

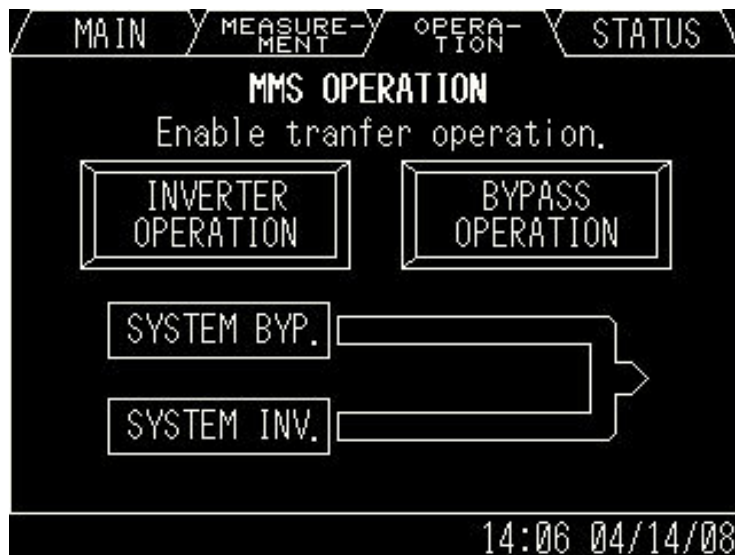
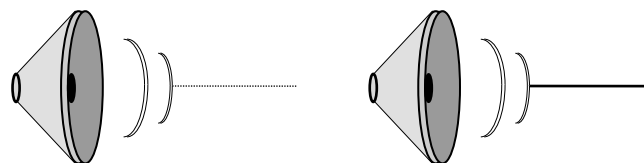
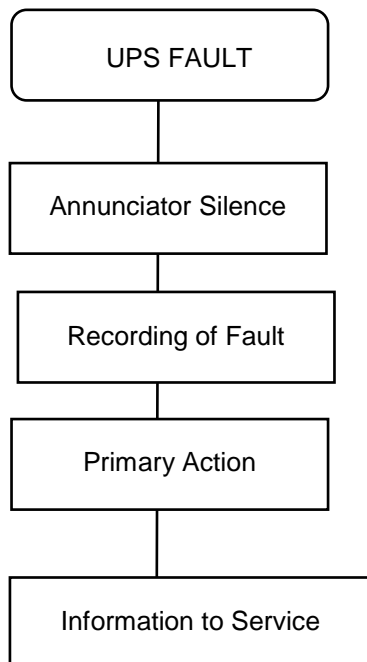

Figure 5-22 LCD Screen (MMS Operation)

6 RESPONSE TO UPS FAILURE



Depress "SILENCE ALARM" icon on Main Menu.

Refer to the list of fault codes in section 6.0 for error description.

Take necessary action according to display guidance.

When faults happen, contact the Authorized Toshiba Service Representatives or call Toshiba International Corporation at **1-877-867-8773**.



NOTE

Note

The error code indicated on the LCD display panel when an UPS alarms is very important. In order to reduce repair time, please include this information, along with the operation and load status for all correspondence to Toshiba field service group.

7 PARTS REPLACEMENT

A) Recommended Maintenance

Toshiba International Corporation recommends the UPS have regular preventative maintenance (PM) visits to ensure optimum operation and longevity. Toshiba recommends two Major PM's per year, at six month intervals.

A Major PM includes maintenance of the batteries and an offline inspection of the UPS. Contact Toshiba International Corporation Service Department at 1-877-867-8773 for further details.

B) Battery

Battery lifetime may vary according to the frequency of use and the average ambient operating temperature. The end of battery life is defined as the state of charge resulting in an ampere-hour capacity less than, or equal to, 80% of nominal capacity.

Battery replacement is recommended if its capacity is within this percentage.

C) UPS Component Parts

UPS components have a defined life expectancy (Fans, Capacitors, Filters, etc.)

Contact Toshiba International Corporation or its authorized service representatives for a complete parts replacement schedule. Recommended replacement time interval varies with operating environment.

Contact Toshiba International Corporation or its authorized service representatives for application specific recommendations.

Table 7-1 Standard Replacement Parts List

Parts name	Life Expectancy
Cooling fans	5 years
Electrolytic Capacitors	15 years
AC filter Capacitors	15 years
Control Relays	15 years
Contactors	15 years
PCB	15 years
Control power supply	15 years
LCD	10 years
Fuses	10 years
Thermal relays	10 years



Any parts replacements (including modification) without authorized by Toshiba could result in personal injuries, death or destruction of the UPS.

D) Air Filters

Air filters can be obtained in bulk quantities from Toshiba International Corporation. Use only air filters specified by Toshiba.

Table 7-2 Air Filters

UNIT	Toshiba Part Number	Quantity (per unit)
100 kVA	T90-AF-24x30x1	1
160 kVA	T90-AF-15x30x1	2
225 kVA		2
300 kVA		2
500 kVA	T90-AF-24x30x1	1 (left door)
	T90-AF-20x30x1	1 (right door)
650 kVA	T90-AF-15x30x1	4
750 kVA	T90-AF-15x30x1	4

8 FAULT CODES

This section covers fault codes, their description and required action at time of error.

Verify and record the occurrence of the alarm. Note details of alarm message displayed on the LCD display panel.

Contact Toshiba International Corporation at 1-877-867-8773.

Failure Code List

Table 8–1 Fault Code

Note 3 Code indication	Status message	Meaning	Guidance	Buzzer	Note 1 External relay contact	Note 2 Failure lamp
UA801	AC INPUT VOLTAGE OUT OF RANGE	Input line voltage is out of the specified range.	CHECK INPUT POWER SOURCE	Intermittent sound	Alarm AC input abnormal	—
UA802	AC INPUT FREQUENCY OUT OF RANGE	Input line frequency is out of the specified range.	CHECK INPUT POWER SOURCE	Intermittent sound	Alarm AC input abnormal	—
UA803	AC INPUT PHASE ROTATION ERROR	Input line power conductors are not wired in a proper phase sequence.	CHECK INPUT POWER SOURCE	Intermittent sound	Alarm AC input abnormal	—
UA804	CONVERTER OPE. PROHIBITED	The converter interlock is active.	—	Intermittent sound	Alarm	—
UA805	INVERTER OVERLOAD	The output load current has exceeded 105% of the rated current.	WARNING : DECREASE LOAD	Intermittent sound	Alarm Overload	—
UA806	INVERTER OVERLOAD	The output load current has exceeded 110% of the rated current.	WARNING : DECREASE LOAD	Intermittent sound	Alarm Overload	—
UA807	INVERTER OVERLOAD	The output load current has exceeded 125% of the rated current.	WARNING : DECREASE LOAD	Intermittent sound	Alarm Overload	—
UA808	INVERTER OVERLOAD	The output load current has exceeded 150% of the rated current.	WARNING : DECREASE LOAD	Intermittent sound	Alarm Overload	—
UA810	INVERTER OVERLOAD	Short time over-current has been detected during the inverter operation.	WARNING : DECREASE LOAD	Intermittent sound	Alarm Overload	—
UA812	BYPASS VOLTAGE OUT OF RANGE	Bypass line voltage is out of the specified range.	CHECK BYPASS INPUT	Intermittent sound	Alarm Bypass input abnormal	—
UA813	BYPASS PHASE ROTATION ERROR	Bypass line power conductors are not wired in a proper phase sequence.	CHECK BYPASS INPUT	Intermittent sound	Alarm Bypass input abnormal	—
UA814	BYPASS FREQUENCY OUT OF RANGE	Bypass line frequency is out of the specified range.	CHECK BYPASS INPUT	Intermittent sound	Alarm Bypass input abnormal	—
UA815	TRANSFER PROHIBITED	Transfer to the bypass is not available due to bypass abnormality.	—	Intermittent sound	Alarm	—
UA817	EMERGENCY STOP ACTIVATED	The emergency stop was activated by the EPO switch or an external contact.	—	—	Alarm	—
UA821	TRANSFER PROHIBITED	The UPS could not transfer to the bypass because the inverter output was not synchronized to the bypass.	—	—	Alarm	—
UA822	TRANSFER PROHIBITED	The UPS could not transfer to the bypass because external "generator operation" signal indicates a backup generator is in operation.	—	—	Alarm	—

Note 3 Code indication	Status message	Meaning	Guidance	Buzzer	Note 1 External relay contact	Note 2 Failure lamp
UA824	CB2 OPEN	The battery circuit breaker (CB2) is open.	TURN ON CB2	Intermittent sound	Alarm	—
UA827	52C OPEN PROHIBITED	The interlock for the inverter output contactor (52C) is active.	—	Intermittent sound	Alarm	—
UA831	EMERGENCY BYPASS SWITCH ON	Emergency bypass switch has been turned on.	—	Intermittent sound	Alarm	—
UA833	52L OPEN	The load circuit breaker (52L) is turned off.	—	Intermittent sound	Alarm	—
UA834	BATTERY DEPLETED/AC OUT STOPPED	The battery voltage has reached the depleted level.	—	—	Major End-of-Discharge	Lit on
UA835	TRANSFER PROHIBITED	The UPS could not transfer to the bypass because the bypass source has an abnormality.	—	—	Alarm	—
UA860	REMOTE BUTTON ABNORMAL	Remote start or stop signal is being received continuously for a considerable time.	—	Intermittent sound	Alarm	—
UA861	LOCAL BUTTON ABNORMAL	Local start or stop signal is being received continuously for a considerable time.	—	Intermittent sound	Alarm	—
UA870	BALANCER OVERLOAD	The UPS detected a neutral point voltage unbalance.	—	Intermittent sound	Alarm Overload	—
UA890	EXTERNAL ALARM	External Alarm relay turned on.	—	Intermittent sound	Alarm	—
UF001	INPUT CIRCUIT ABNORMAL	The MMS input reference error signal exceeds specifications.	CALL SERVICE ENGINEER	Continuous sound	Major	Lit on
UF002	CONVERTER OVERCURRENT	Detection of MMS converter overcurrent.	CALL SERVICE ENGINEER	Continuous sound	Major	Lit on
UF003	CONVERTER ABNORMAL	Pre-charging circuit is not working properly.	CALL SERVICE ENGINEER	Continuous sound	Major	Lit on
UF011	CB1 ABNORMAL	Major discrepancy between reference signal and actual state of contactor CB1.	CALL SERVICE ENGINEER	Continuous sound	Major	Lit on
UF052	CB1 ABNORMAL	Minor discrepancy between reference signal and actual state of contactor CB1.	CALL SERVICE ENGINEER	Intermittent sound	Minor	Flicker
UF056	CONVERTER OVERCURRENT	Detection of SMS converter overcurrent.	CALL SERVICE ENGINEER	Intermittent sound	Minor	Flicker
UF059	INPUT CIRCUIT ABNORMAL	The SMS input reference error signal exceeds specifications.	CALL SERVICE ENGINEER	Intermittent sound	Minor	Flicker
UF102	DC OVERVOLTAGE	DC voltage surpasses the overvoltage level.	CALL SERVICE ENGINEER	Continuous sound	Major	Lit on
UF103	DC UNDERVOLTAGE	DC voltage dropped below the undervoltage level.	CALL SERVICE ENGINEER	Continuous sound	Major	Lit on
UF108	CHOPPER OVERCURRENT	Detection of DC overcurrent from backup battery.	CALL SERVICE ENGINEER	Continuous sound	Major	Lit on

Note 3 Code indication	Status message	Meaning	Guidance	Buzzer	Note 1 External relay contact	Note 2 Failure lamp
UF109	DC UNBALANCED	Major unbalance of the neutral point voltage.	CALL SERVICE ENGINEER	Continuous sound	Major	Lit on
UF110	ZERO PHASE OVERCURRENT	Detection of converter zero-sequence overcurrent.	CALL SERVICE ENGINEER	Continuous sound	Major	Lit on
UF111	UPS CONTROL CIRCUIT ERROR	Battery current unbalance.	CALL SERVICE ENGINEER	Continuous sound	Major	Lit on
UF112	DC CIRCUIT ABNORMAL	Sudden change of the DC voltage level.	CALL SERVICE ENGINEER	Continuous sound	Major	Lit on
UF119	DC GROUND FAULT	Detection of DC ground fault UF159 exceeds 10 seconds. UPS transfers to bypass.	CALL SERVICE ENGINEER	Continuous sound	Major	Lit on
UF128	CONTROL POWER SUPPLY ABNORMAL	Power supply voltage to IGBT driver PCB is below the specified level.	CALL SERVICE ENGINEER	Continuous sound	Major	Lit on
UF151	DC VOLTAGE ABNORMAL	24 hours after input power restoration, batteries do not reach float voltage level.	CALL SERVICE ENGINEER	Intermittent sound	Minor	Flicker
UF152	DC VOLTAGE ABNORMAL	Unable to equalize the voltage of various batteries after 24 hours.	CALL SERVICE ENGINEER	Intermittent sound	Minor	Flicker
UF154	CB2 ABNORMAL	During UVR, status signal from CB2 is ON.	CALL SERVICE ENGINEER	Intermittent sound	Minor	Flicker
UF156	CHG.STOPPED (BATTERY OVERTEMP.)	UF157 failure persisted for over 2 hours.	CHECK BATTERY	Intermittent sound	Minor Battery abnormal	Flicker
UF157	BATTERY OVERTEMPERATURE	Detection of overtemperature at the batteries.	CHECK BATTERY	Intermittent sound	Minor Battery abnormal	Flicker
UF158	BATTERY LIQUID LOW	Low level of battery electrolyte solution.	CHECK BATTERY	Intermittent sound	Minor Battery abnormal	Flicker
UF159	DC GROUND FAULT	Detection of DC ground fault. Chopper operation is stopped.	CALL SERVICE ENGINEER	Intermittent sound	Minor	Flicker
UF160	UPS CONTROL CIRCUIT ERROR	Abnormal behavior of DC current sensor.	CALL SERVICE ENGINEER	Intermittent sound	Minor	Flicker
UF161	CHG.STOPPED(DC VOLT. ABNORMAL)	UF151 failure is running for over 24 hours.	CALL SERVICE ENGINEER	Intermittent sound	Minor	Flicker
UF162	BATTERY ABNORMAL	Failure detection based on battery self-check.	CALL SERVICE ENGINEER	Intermittent sound	Minor	Flicker
UF163	BATTERY VOLTAGE ABNORMAL	Battery voltage is abnormal.	CALL SERVICE ENGINEER	Intermittent sound	Minor	Flicker
UF170	VDB SENSOR ABNORMAL	Detection of a large variation of the difference between control-only and protection-only battery voltage.	CALL SERVICE ENGINEER	Intermittent sound	Minor	Flicker
UF171	UPS CONTROL CIRCUIT ERROR	Poor shared current in parallel chopper circuit; or improper charging current.	CALL SERVICE ENGINEER	Intermittent sound	Minor	Flicker
UF172	CHG. STOPPED (DEVICE STATUS)	Energy storage device error.	CALL SERVICE ENGINEER	Intermittent sound	Minor	Flicker

Note 3 Code indication	Status message	Meaning	Guidance	Buzzer	Note 1 External relay contact	Note 2 Failure lamp
UF201	INVERTER OVERVOLTAGE	Detection of output overvoltage.	CALL SERVICE ENGINEER	Continuous sound	Major	Lit on
UF202	INVERTER UNDERVOLTAGE	Output voltage dropped below specs.	CALL SERVICE ENGINEER	Continuous sound	Major	Lit on
UF203	INVERTER OVERCURRENT	Detection of inverter overcurrent.	CALL SERVICE ENGINEER	Continuous sound	Major	Lit on
UF204	OUTPUT CIRCUIT ABNORMAL	Detection of a large variation of the reference error signal (current reference and actual current).	CALL SERVICE ENGINEER	Continuous sound	Major	Lit on
UF206	UPS CONTROL CIRCUIT ERROR	Discrepancy between output voltage and external voltage (bypass, common ac bus)	CALL SERVICE ENGINEER	Continuous sound	Major	Lit on
UF207	ZERO PHASE OVERCURRENT	Inverter zero-sequence overcurrent.	CALL SERVICE ENGINEER	Continuous sound	Major	Lit on
UF208	UPS CONTROL CIRCUIT ERROR	Cross current is abnormal.	CALL SERVICE ENGINEER	Continuous sound	Major	Lit on
UF209	52C ABNORMAL	Error to close the contactor 52C.	CALL SERVICE ENGINEER	Continuous sound	Major	Lit on
UF210	52C ABNORMAL	Error to open the contactor 52C.	CALL SERVICE ENGINEER	Continuous sound	Major	Lit on
UF211	52C ABNORMAL	No answer from contactor 52C during inverter operation.	CALL SERVICE ENGINEER	Continuous sound	Major	Lit on
UF213	OVERTEMP	Heatsink's temperature exceeds thermal settings.	CALL SERVICE ENGINEER	Continuous sound	Major	Lit on
UF214	COOLING FAN ABNORMAL	Thermal relay activated protection.	CALL SERVICE ENGINEER	Continuous sound	Major	Lit on
UF217	INVERTER OVERVOLTAGE	Detection of inverter output phase overvoltage.	CALL SERVICE ENGINEER	Continuous sound	Major	Lit on
UF230	ZERO PHASE OVERCURRENT	Detection of zero-sequence overcurrent.	CALL SERVICE ENGINEER	Continuous sound	Major	Lit on
UF253	UPS CONTROL CIRCUIT ERROR	Discrepancy between output voltage and inverter voltage, or between output voltage and bypass voltage.	CALL SERVICE ENGINEER	Intermittent sound	Minor	Flicker
UF256	OUTPUT VOLTAGE ABNORMAL	Output voltage is outside of the specified range.	CALL SERVICE ENGINEER	Intermittent sound	Minor	Flicker
UF257	52C ABNORMAL	Contactor 52C failed to open during load transfer from inverter to bypass.	CALL SERVICE ENGINEER	Intermittent sound	Minor	Flicker
UF258	LOAD ABNORMAL	Load transfer due to overload for over 4 times within 5 minutes.	CALL SERVICE ENGINEER	Intermittent sound	Minor	Flicker
UF259	ANOTHER UPS ABNORMAL	No detection of another UPS voltage signal.	CALL SERVICE ENGINEER	Intermittent sound	Minor	Flicker

Note 3 Code indication	Status message	Meaning	Guidance	Buzzer	Note 1 External relay contact	Note 2 Failure lamp
UF301	UPS CONTROL CIRCUIT ERROR	AD reference has an abnormal value.	CALL SERVICE ENGINEER	Continuous sound	Major	Lit on
UF302	UPS CONTROL CIRCUIT ERROR	Detection of an external interruption during the software execution.	CALL SERVICE ENGINEER	Continuous sound	Major	Lit on
UF303	UPS CONTROL CIRCUIT ERROR	Timer does not reset in the specified period (WDT settings)	CALL SERVICE ENGINEER	Continuous sound	Major	Lit on
UF305	UPS CONTROL CIRCUIT ERROR	Detection of an abnormal clock speed in the DSP or FPGA.	CALL SERVICE ENGINEER	Continuous sound	Major	Lit on
UF306	UPS CONTROL CIRCUIT ERROR	Control power supply voltage is below the specified level.	CALL SERVICE ENGINEER	Continuous sound	Major	Lit on
UF309	INVERTER VOLTAGE ABNORMAL	Inverter voltage is out of the specified range.	CALL SERVICE ENGINEER	Continuous sound	Major	Lit on
UF310	CONTROL POWER SUPPLY ABNORMAL	MMS backup control power supplies exhibit abnormal condition.	CALL SERVICE ENGINEER	Continuous sound	Major	Lit on
UF320	UPS CONTROL CIRCUIT ERROR	Cable disconnection in the parallel interface board during load supply.	CALL SERVICE ENGINEER	Continuous sound	Major	Lit on
UF323	UPS CONTROL CIRCUIT ERROR	Major communication error during parallel operation.	CALL SERVICE ENGINEER	Continuous sound	Major	Lit on
UF331	UPS CONTROL CIRCUIT ERROR	Gate driver abnormal for phase U (Note 4)	CALL SERVICE ENGINEER	Continuous sound	Major	Lit on
UF332	UPS CONTROL CIRCUIT ERROR	Gate driver abnormal for phase V (Note 4)	CALL SERVICE ENGINEER	Continuous sound	Major	Lit on
UF333	UPS CONTROL CIRCUIT ERROR	Gate driver abnormal for phase W (Note 4)	CALL SERVICE ENGINEER	Continuous sound	Major	Lit on
UF334	UPS CONTROL CIRCUIT ERROR	Gate driver abnormal for chopper (Note 4)	CALL SERVICE ENGINEER	Continuous sound	Major	Lit on
UF352	CONTROL POWER SUPPLY ABNORMAL	SMS backup control power supplies exhibit abnormal.	CALL SERVICE ENGINEER	Intermittent sound	Minor	Flicker
UF363	UPS CONTROL CIRCUIT ERROR	Synchronization error signal is being received for a considerable time.	CALL SERVICE ENGINEER	Intermittent sound	Minor	Flicker
UF371	UPS CONTROL CIRCUIT ERROR	Minor communication error during parallel operation.	CALL SERVICE ENGINEER	Intermittent sound	Minor	Flicker
UF372	UPS CONTROL CIRCUIT ERROR	Unable to synchronize the inverter output and the bypass voltage when the bypass is normal.	CALL SERVICE ENGINEER	Intermittent sound	Minor	Flicker
UF374	UPS CONTROL CIRCUIT ERROR	Cable disconnection in the parallel interface board.	CALL SERVICE ENGINEER	Intermittent sound	Minor	Flicker
UF375	UPS CONTROL CIRCUIT ERROR	Unable to achieve synchronization for parallel operation.	CALL SERVICE ENGINEER	Intermittent sound	Minor	Flicker
UF376	UPS CONTROL CIRCUIT ERROR	No control response from another UPS although its detection is possible.	CALL SERVICE ENGINEER	Intermittent sound	Minor	Flicker
UF377	UPS CONTROL CIRCUIT ERROR	Overload detection signal is being received continuously for a considerable time.	CALL SERVICE ENGINEER	Intermittent sound	Minor	Flicker
UF378	UPS CONTROL CIRCUIT ERROR	No answer for sending synchronizing signal.	CALL SERVICE ENGINEER	Intermittent sound	Minor	Flicker
UF379	UPS CONTROL CIRCUIT ERROR	Abnormal clock speed of the parallel control board processor.	CALL SERVICE ENGINEER	Intermittent sound	Minor	Flicker

Note 3 Code indication	Status message	Meaning	Guidance	Buzzer	Note 1 External relay contact	Note 2 Failure lamp
UF401	52S ABNORMAL	Error to close the contactor 52S.	CALL SERVICE ENGINEER	Continuous sound	Major	Lit on
UF402	52S ABNORMAL	Error to open the contactor 52S.	CALL SERVICE ENGINEER	Continuous sound	Major	Lit on
UF420	52L OPERATION ERROR	Load circuit breaker 52L opened during inverter operation.	CHECK 52L	Continuous sound	Major	Lit on
UF451	52S ABNORMAL	Contactor 52S failed during load transfer from inverter to bypass.	CALL SERVICE ENGINEER	Intermittent sound	Minor	Flicker
UF452	CB3 ABNORMAL	Contactor CB3 is not working properly.	CALL SERVICE ENGINEER	Intermittent sound	Minor	Flicker

- (Note 1) 1) "Major" is defined as major failure. Inverter transferred to the static bypass line;
2) "Minor" is defined as a minor failure. UPS continues to operate normally, but cause of alarm must be identified;

(Note 2) Indicates one of two possible LED illumination patterns - continuously on (lit) or intermittent (flicker).

(Note 3) Code indication means:

UA+++----- Alarm
 UF+++----- Failure
 U%0++----- Rectifier circuit failure
 U%1++----- DC circuit failure
 U%2++----- Inverter circuit failure
 U%3++----- Control circuit failure
 U%4++----- Bypass system failure
 U%8++----- Alarm
 U%+00 - U%+49 ----- Major failure
 U%+50 - U%+99 ----- Minor failure

*) "+" denotes any numeral from 0 to 9

*) "%" denotes either "A" or "F"

9 DAILY INSPECTION

Please perform the daily inspection while the UPS is running. The daily inspection items are shown in Table 9.1.



NOTE

The customers can only inspect exterior or environment of cabinet. When the customers want to perform the detailed inspection, contact the Authorized Toshiba Service Representatives or call Toshiba International Corporation at 1-877-867-8773.

Table 9–1 How to Perform Daily Inspection

No.	Subject	Procedure			Criteria and/or Action needed
		Term	Period	Method/Tool	
1.	Environmental ambient	Dust or Gas	Daily	Visual check and smelling	Ventilate room atmosphere if dusty or smelling gas.
		Dewdrops Condensation	Daily	Visual check	Fix the dripping source Dehumidify upon necessity.
		Temperature Humidity	Daily	Thermometer hygrometer	Temperature: 32 – 104 °F Humidity: 30 – 90% No condensation. To be controlled at about 77 °F by A/C.
2.	Cabinet Construction	Vibration or Audible noise	Daily	Touch and hearing	Check if fans have irregular sound. Contact service representative in case of abnormalities.
		Overheating	When needed	Touching exterior	Contact service representative in case of abnormalities.
		Air filter clog	When needed	Visual check	Clean/wipe if clogged or dusty.
3.	Operation	LCD sharpness Brightness Left-bottom LED	Daily	Visual check	No characters faded, illegible, or any other abnormalities. Left-bottom LED should be green. Contact service representative when the LED shows red with the backlight lost.
		Indication terms: Output voltage Output current AC input voltage Output frequency Battery voltage Battery current DC voltage	Daily	Visual check	Check indication terms/values if within the adequate window. Also check indication meters on surface of optional cabinet, if installed.
4.	LEDs	4 status LEDs	Daily	Visual check	Check if LEDs turn on, off or flash according to the operation.
		2 fault LEDs	Daily	Visual check	If UPS fault LED turns on, scroll the screen to see fault codes and record the codes. Contact service representative to tell about fault codes and UPS symptom.

APPENDIX A – Installation Planning Guides (IPG)

Installation Planning Guide for 100kVA UPS

Standard System: 480V Input, 480V Output

General Mechanical Information									
Dimensions (W x D x H)		Weight	Floor Loading	Approximate Full-Load Heat Rejection	Mechanical Clearance (Inches) from UPS for Ventilation and Maintenance Access				
Inches		Lbs.	Lbs./ft. ²	Btu/Hr.	Top	Front	Bottom	Sides**	Back
27.6" x 32.8" x 80.6"*		855	136	13,463	20"	40"	0"	0"	0"

* Height includes removable fan housing – Frame height is 78.7."

** 0" clearance for peripheral equipment, 1" clearance for walls.

Primary AC Input (480V 3-Phase / 3-Wire)				
Maximum Input Power Demand Normal Mode (Recharge Mode)			Suggested External Overcurrent Protection	External Feeder Wire Size: Min. – Max. Per Phase
kVA	PF	Amps	Amps	AWG or kcmil at 75° C Temp. Rating
95 (107)	>0.99	114 (129)	150 AT	2/0 – 3/0

Alternate (Bypass) AC Input (480V 3-Phase / 3-Wire)				
Maximum Input Power Demand			Suggested External Overcurrent Protection	External Feeder Wire Size: Min. – Max. Per Phase
kVA	PF	Amps	Amps	AWG or kcmil at 75° C Temp. Rating
100	0.9	120	150 AT	2/0 – 3/0

Battery Input (480VDC Nominal)		
Battery Capacity Required for Full Load Output	Suggested External Overcurrent Protection	One (1) Cabinet: DC Cable Size per Cabinet***
kWB	Amps	AWG or kcmil at 75° C Temp. Rating
94 @ 0.9 PF	N/A – Toshiba-Supplied Battery Cabinets equipped with built-in overcurrent Protection	1 x 250 kcmil – 300 kcmil

*** Contact Toshiba Factory Representative for multiple Battery Cabinet Configurations.

AC Output (480/277V 3-Phase / 3-Wire)				
Rated Output Power			Suggested External Overcurrent Protection	External Feeder Wire Size: Min. – Max. Per Phase
kVA	PF	Amps	Amps	AWG or kcmil at 75° C Temp. Rating
100	0.9	120	150AT	2/0 – 3/0

Important Notes:

- Maximum input current is limited to 106% of the full-load input current.
- Output load conductors are to be installed in separate conduit from input conductors.
- Control wires and power wires are to be installed in separate conduits.
- Recommended AC input and output overcurrent protection based on continuous full load current per NEC.
- Wiring shall comply with all applicable national and local electrical codes.
- Grounding conductors to be sized per NEC Article 250-122. Neutral conductors to be sized per NEC Article 310.15.
 - Primary AC Input: 3φ, 3-wire + ground.
 - Alternate AC Input: 3φ, 3-wire + ground.
 - AC Output: 3φ, 3-wire + ground.
 - DC Input: 2-wire (Positive/Negative) + ground.
- Nominal battery voltage based on the use of VRLA type batteries (2.0 volts/cell nominal).
- Maximum battery discharge current based on lowest permissible discharge voltage of 1.67 VPC.
- DC wires should be sized to allow not more than a 2-volt drop at maximum discharge current.
- Weights do not include batteries or other auxiliary equipment external to the UPS.

- Cable sizing calculations based on the following assumptions:
 - Minimum size is smallest size based on ampacity at 30 °C.
 - Maximum size cable is based on cable bend radius limitations at the UPS terminals.
 - Not more than 3 current-carrying conductors installed in conduit in ambient temperature of 30 °C.
 - Temperature rating of copper conductors/terminals: 75 °C in conduit.
 - Reference: 2005 NEC Handbook, Table 310.16.

NOTE: Consult latest edition of applicable national and local codes for possible variations.
- Ratings of wires and overcurrent devices are suggested minimums. Consult with a registered Professional Engineer within your local area for proper size selections.

TOSHIBA INTERNATIONAL CORPORATION
13131 West Little York Road
Houston, TX 77041
Telephone: (800) 231-1412
Fax: (713) 896-5212
Web Site: www.toshiba.com/ind

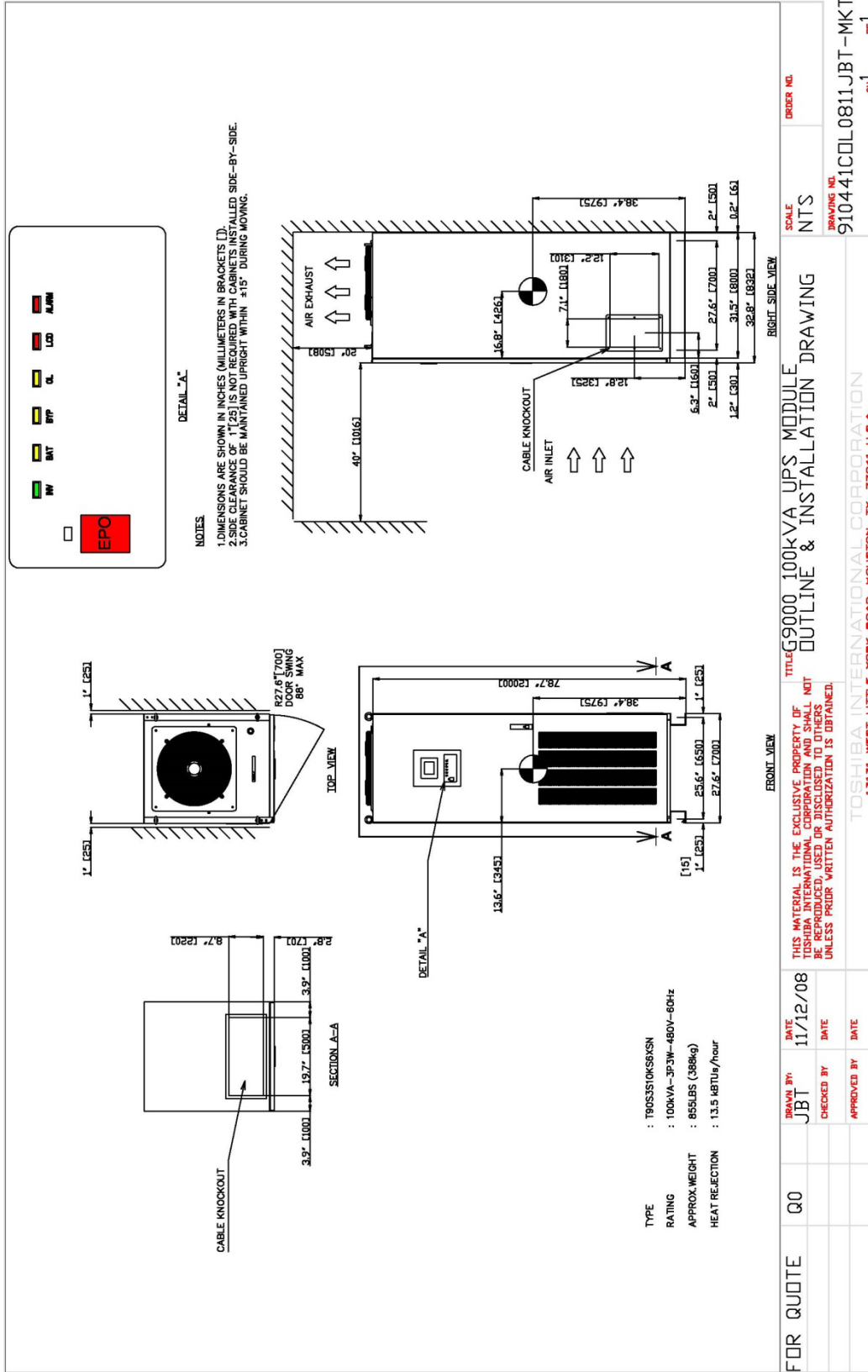

Installation Planning Guide for 160kVA UPS

Standard System: 480V Input, 480V Output

General Mechanical Information									
Dimensions (W x D x H)		Weight	Floor Loading	Approximate Full-Load Heat Rejection	Mechanical Clearance (Inches) from UPS for Ventilation and Maintenance Access				
Inches		Lbs.	Lbs./ft. ²	Btu/Hr.	Top	Front	Bottom	Sides**	Back
35.4" x 32.8" x 80.6"		1160	144	17,821	20"	40"	0"	0"	0"

* Height includes removable fan housing – Frame height is 78.7".

** 0" clearance for peripheral equipment, 1" clearance for walls.

Primary AC Input (480V 3-Phase / 3-Wire)				
Maximum Input Power Demand Normal Mode (Recharge Mode)			Suggested External Overcurrent Protection	External Feeder Wire Size: Min. – Max. Per Phase
kVA	PF	Amps	Amps	AWG or kcmil at 75° C Temp. Rating
151 (170)	>0.99	181 (204)	250 AT	250 kcmil – 300 kcmil

Alternate (Bypass) AC Input (480V 3-Phase / 3-Wire)				
Maximum Input Power Demand			Suggested External Overcurrent Protection	External Feeder Wire Size: Min. – Max. Per Phase
kVA	PF	Amps	Amps	AWG or kcmil at 75° C Temp. Rating
160	0.9	192	250 AT	250 kcmil – 300 kcmil

Battery Input (480VDC Nominal)				
Battery Capacity Required for Full Load Output		Suggested External Overcurrent Protection		One (1) Cabinet: DC Cable Size per Cabinet***
kWB		Amps		AWG or kcmil at 75° C Temp. Rating
149 @ 0.9 PF		N/A – Toshiba-Supplied Battery Cabinets equipped with built-in overcurrent Protection		1 x 500 kcmil – 1 x 600 kcmil

*** Contact Toshiba Factory Representative for multiple Battery Cabinet Configurations.

AC Output (480V 3-Phase / 3-Wire)				
Rated Output Power			Suggested External Overcurrent Protection	External Feeder Wire Size: Min. – Max. Per Phase //
kVA	PF	Amps	Amps	AWG or kcmil at 75° C Temp. Rating
160	0.9	192	250 AT	250 kcmil – 300 kcmil

Important Notes:

1. Maximum input current is limited to 106% of the full-load input current.
2. Output load conductors are to be installed in separate conduit from input conductors.
3. Control wires and power wires are to be installed in separate conduits.
4. Recommended AC input and output overcurrent protection based on continuous full load current per NEC.
5. Wiring shall comply with all applicable national and local electrical codes.
6. Grounding conductors to be sized per NEC Article 250-122. Neutral conductors to be sized per NEC Article 310.15.
 - Primary AC Input: 3 ϕ , 3-wire + ground.
 - Alternate AC Input: 3 ϕ , 3-wire + ground.
 - AC Output: 3 ϕ , 3-wire + ground.
 - DC Input: 2-wire (Positive/Negative) + ground.
7. Nominal battery voltage based on the use of VRLA type batteries (2.0 volts/cell nominal).
8. Maximum battery discharge current based on lowest permissible discharge voltage of 1.67 VPC.
9. DC wires should be sized to allow not more than a 2-volt drop at maximum discharge current.
10. Weights do not include batteries or other auxiliary equipment external to the UPS.

11. Cable sizing calculations based on the following assumptions:
 - Minimum size is smallest size based on ampacity at 30 °C.
 - Maximum size cable is based on cable bend radius limitations at the UPS terminals.
 - Not more than 3 current-carrying conductors installed in conduit in ambient temperature of 30 °C.
 - Temperature rating of copper conductors/terminals: 75 °C in conduit.
 - Reference: 2005 NEC Handbook, Table 310.16.

NOTE: Consult latest edition of applicable national and local codes for possible variations.
12. Ratings of wires and overcurrent devices are suggested minimums. Consult with a registered Professional Engineer within your local area for proper size selections.

TOSHIBA INTERNATIONAL CORPORATION
 13131 West Little York Road
 Houston, TX 77041
 Telephone: (800) 231-1412
 Fax: (713) 896-5212
 Web Site: www.toshiba.com/ind

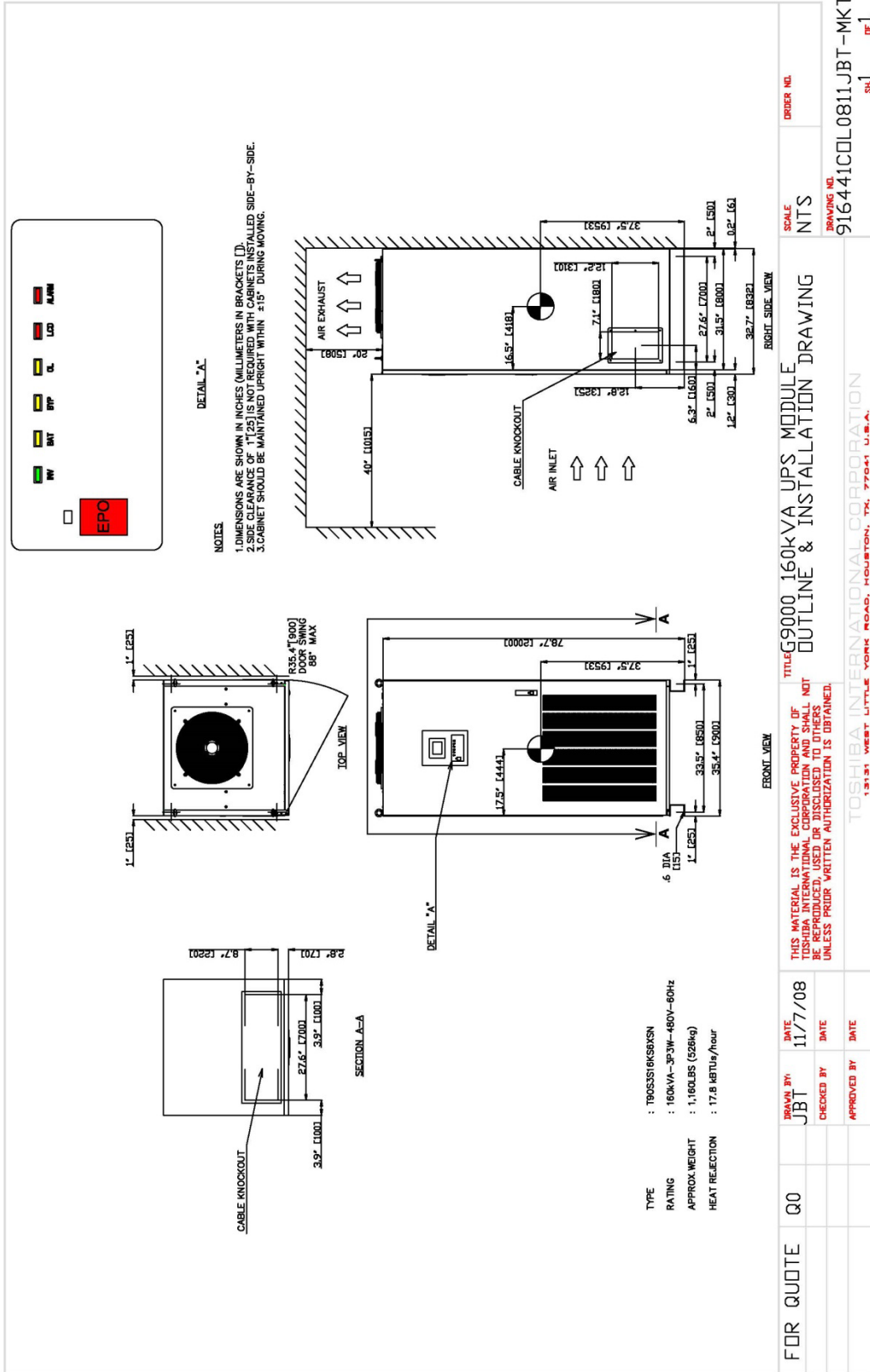

Installation Planning Guide for 225kVA UPS

Standard System: 480V Input, 480V Output

General Mechanical Information									
Dimensions (W x D x H)		Weight	Floor Loading	Approximate Full-Load Heat Rejection	Mechanical Clearance (Inches) from UPS for Ventilation and Maintenance Access				
Inches		Lbs.	Lbs./ft. ²	Btu/Hr.	Top	Front	Bottom	Sides**	Back
35.4" x 32.8" x 80.6"		1230	152	25,060	20"	40"	0"	0"	0"

* Height includes removable fan housing – Frame height is 78.7".

** 0" clearance for peripheral equipment, 1" clearance for walls.

Primary AC Input (480V 3-Phase / 3-Wire)				
Maximum Input Power Demand Normal Mode (Recharge Mode)			Suggested External Overcurrent Protection	External Feeder Wire Size: Min. – Max. Per Phase
kVA	PF	Amps	Amps	AWG or kcmil at 75° C Temp. Rating
212 (238)	>0.99	255 (286)	350 AT	500 kcmil – (2) x 250 kcmil

Alternate (Bypass) AC Input (480V 3-Phase / 3-Wire)				
Maximum Input Power Demand			Suggested External Overcurrent Protection	External Feeder Wire Size: Min. – Max. Per Phase
kVA	PF	Amps (Max.)	Amps	AWG or kcmil at 75° C Temp. Rating
225	0.9	271	350 AT	500 kcmil - (2) x 250 kcmil

Battery Input (480VDC Nominal)				
Battery Capacity Required for Full Load Output		Suggested External Overcurrent Protection		One (1) Cabinet: DC Cable Size per Cabinet***
kWB		Amps		AWG or kcmil at 75° C Temp. Rating
210 @ 0.9 PF		N/A – Toshiba-Supplied Battery Cabinets equipped with built-in overcurrent Protection		(2) x 350 kcmil – (2) x 400 kcmil

*** Contact Toshiba Factory Representative for alternate multiple-Battery Cabinet Cabling.

AC Output (480V 3-Phase / 3-Wire)				
Rated Output Power			Suggested External Overcurrent Protection	External Feeder Wire Size: Min. – Max. Per Phase
kVA	PF	Amps	Amps	AWG or kcmil at 75° C Temp. Rating
225	0.9	271	350 AT	500 kcmil – (2) x 250 kcmil

Important Notes:

1. Maximum input current is limited to 106% of the full-load input current.
2. Output load conductors are to be installed in separate conduit from input conductors.
3. Control wires and power wires are to be installed in separate conduits.
4. Recommended AC input and output overcurrent protection based on continuous full load current per NEC.
5. Wiring shall comply with all applicable national and local electrical codes.
6. Grounding conductors to be sized per NEC Article 250-122. Neutral conductors to be sized per NEC Article 310.15.
 - Primary AC Input: 3 ϕ , 3-wire + ground.
 - Alternate AC Input: 3 ϕ , 3-wire + ground.
 - AC Output: 3 ϕ , 3-wire + ground.
 - DC Input: 2-wire (Positive/Negative) + ground.
7. Nominal battery voltage based on the use of VRLA type batteries (2.0 volts/cell nominal).
8. Maximum battery discharge current based on lowest permissible discharge voltage of 1.67 VPC.
9. DC wires should be sized to allow not more than a 2-volt drop at maximum discharge current.
10. Weights do not include batteries or other auxiliary equipment external to the UPS.

11. Cable sizing calculations based on the following assumptions:
 - Minimum size is smallest size based on ampacity at 30 °C.
 - Maximum size cable is based on cable bend radius limitations at the UPS terminals.
 - Not more than 3 current-carrying conductors installed in conduit in ambient temperature of 30 °C.
 - Temperature rating of copper conductors/terminals: 75 °C in conduit.
 - Reference: 2005 NEC Handbook, Table 310.16.

NOTE: Consult latest edition of applicable national and local codes for possible variations.
12. Ratings of wires and overcurrent devices are suggested minimums. Consult with a registered Professional Engineer within your local area for proper size selections.

TOSHIBA INTERNATIONAL CORPORATION
 13131 West Little York Road
 Houston, TX 77041
 Telephone: (800) 231-1412
 Fax: (713) 896-5212
 Web Site: www.toshiba.com/ind

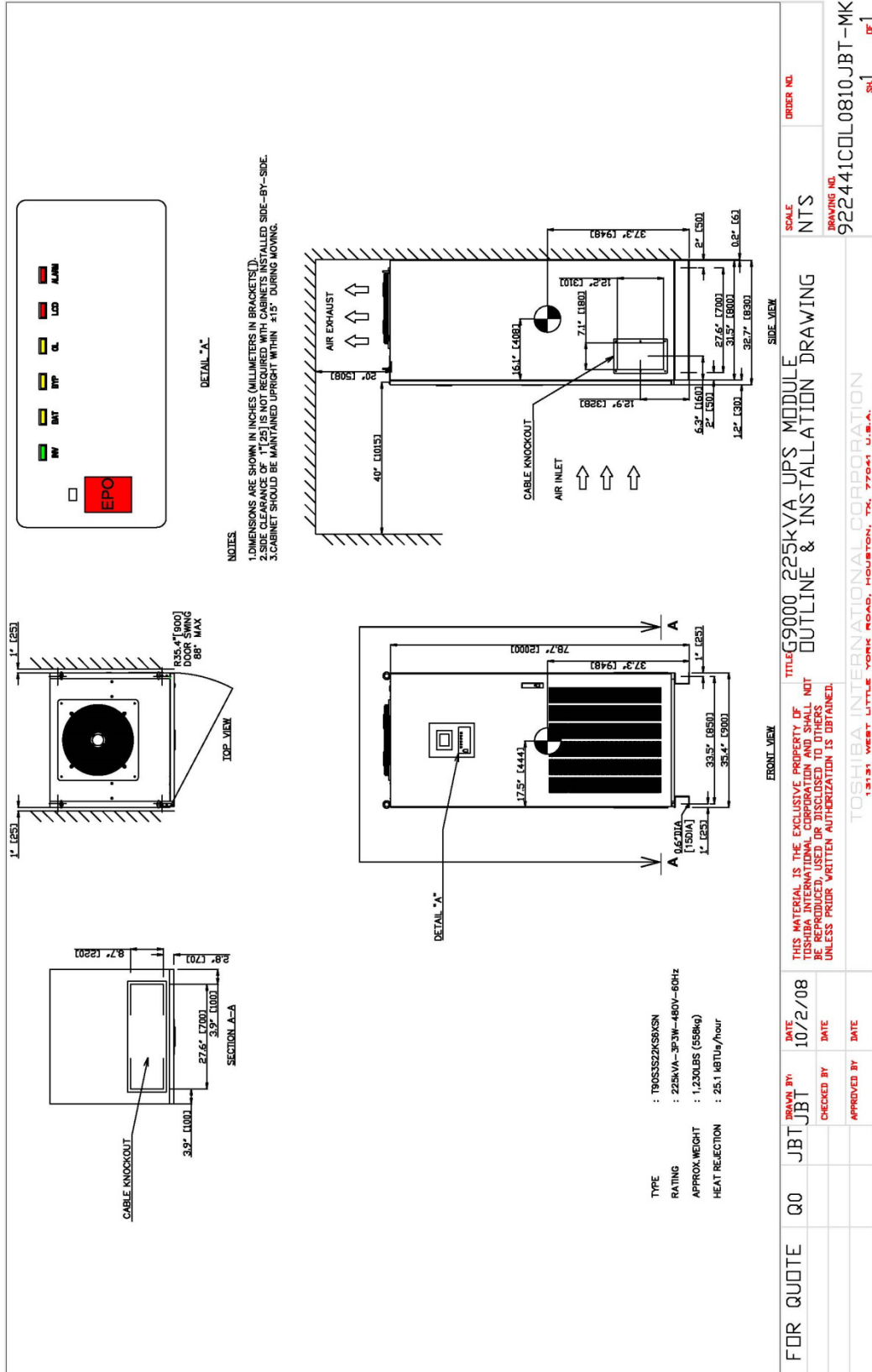

Installation Planning Guide for 300kVA UPS

Standard System: 480V Input, 480V Output

General Mechanical Information									
Dimensions (W x D x H)		Weight	Floor Loading	Approximate Full-Load Heat Rejection	Mechanical Clearance (Inches) from UPS for Ventilation and Maintenance Access				
Inches		Lbs.	Lbs./ft. ²	Btu/Hr.	Top	Front	Bottom	Sides**	Back
51.2" x 32.7" x 80.7"*		1230	189	31,659	23.6"	42.3"	0"	0"	0"

* Height includes removable fan housing – Frame height is 78.7".

** 0" clearance for peripheral equipment, 1" clearance for walls.

Primary AC Input (480V 3-Phase / 3-Wire)				
Maximum Input Power Demand Normal Mode (Recharge Mode)			Suggested External Overcurrent Protection	External Feeder Wire Size: Min. – Max. Per Phase
kVA	PF	Amps	Amps	AWG or kcmil at 75° C Temp. Rating
312 (336)	>0.99	376 (404)	500 AT	(2) x 250 kcmil - (2) x 300 kcmil

Alternate (Bypass) AC Input (480V 3-Phase / 3-Wire)				
Maximum Input Power Demand			Suggested External Overcurrent Protection	External Feeder Wire Size: Min. – Max. Per Phase
kVA	PF	Amps (Max.)	Amps	AWG or kcmil at 75° C Temp. Rating
300	1.0	361	500 AT	(2) x 250 kcmil - (2) x 300 kcmil

Battery Input (480VDC Nominal)				
Battery Capacity Required for Full Load Output		Suggested External Overcurrent Protection		Two (2) Cabinets: DC Cable Size per Cabinet***
kWB		Amps		AWG or kcmil at 75° C Temp. Rating
311 @ 1.0 PF		N/A – Toshiba-Supplied Battery Cabinets equipped with built-in overcurrent Protection		1 x 500 kcmil – 1 x 600 kcmil

*** Contact Toshiba Factory Representative for different multiple Battery Cabinet Configurations.

AC Output (480V 3-Phase / 3-Wire)				
Rated Output Power			Suggested External Overcurrent Protection	External Feeder Wire Size: Min. – Max. Per Phase
kVA	PF	Amps	Amps	AWG or kcmil at 75° C Temp. Rating
300	1.0	361	500 AT	(2) x 250 kcmil - (2) x 300 kcmil

Important Notes:	
<ol style="list-style-type: none"> 1. Maximum input current is limited to 106% of the full-load input current. 2. Output load conductors are to be installed in separate conduit from input conductors. 3. Control wires and power wires are to be installed in separate conduits. 4. Recommended AC input and output overcurrent protection based on continuous full load current per NEC. 5. Wiring shall comply with all applicable national and local electrical codes. 6. Grounding conductors to be sized per NEC Article 250-122. Neutral conductors to be sized per NEC Article 310.15. <ul style="list-style-type: none"> - Primary AC Input: 3ϕ, 3-wire + ground. - Alternate AC Input: 3ϕ, 3-wire + ground. - AC Output: 3ϕ, 3-wire + ground. - DC Input: 2-wire (Positive/Negative) + ground. 7. Nominal battery voltage based on the use of VRLA type batteries (2.0 volts/cell nominal). 8. Maximum battery discharge current based on lowest permissible discharge voltage of 1.67 VPC. 9. DC wires should be sized to allow not more than a 2-volt drop at maximum discharge current. 10. Weights do not include batteries or other auxiliary equipment external to the UPS. 	<ol style="list-style-type: none"> 11. Cable sizing calculations based on the following assumptions: <ul style="list-style-type: none"> - Minimum size is smallest size based on ampacity at 30 °C. - Maximum size cable is based on cable bend radius limitations at the UPS terminals. - Not more than 3 current-carrying conductors installed in conduit in ambient temperature of 30 °C. - Temperature rating of copper conductors/terminals: 75 °C in conduit. - Reference: 2005 NEC Handbook, Table 310.16. <p>NOTE: Consult latest edition of applicable national and local codes for possible variations.</p> 12. Ratings of wires and overcurrent devices are suggested minimums. Consult with a registered Professional Engineer within your local area for proper size selections.
	<p>TOSHIBA INTERNATIONAL CORPORATION 13131 West Little York Road Houston, TX 77041 Telephone: (800) 231-1412 Fax: (713) 896-5212 Web Site: www.toshiba.com/ind</p>

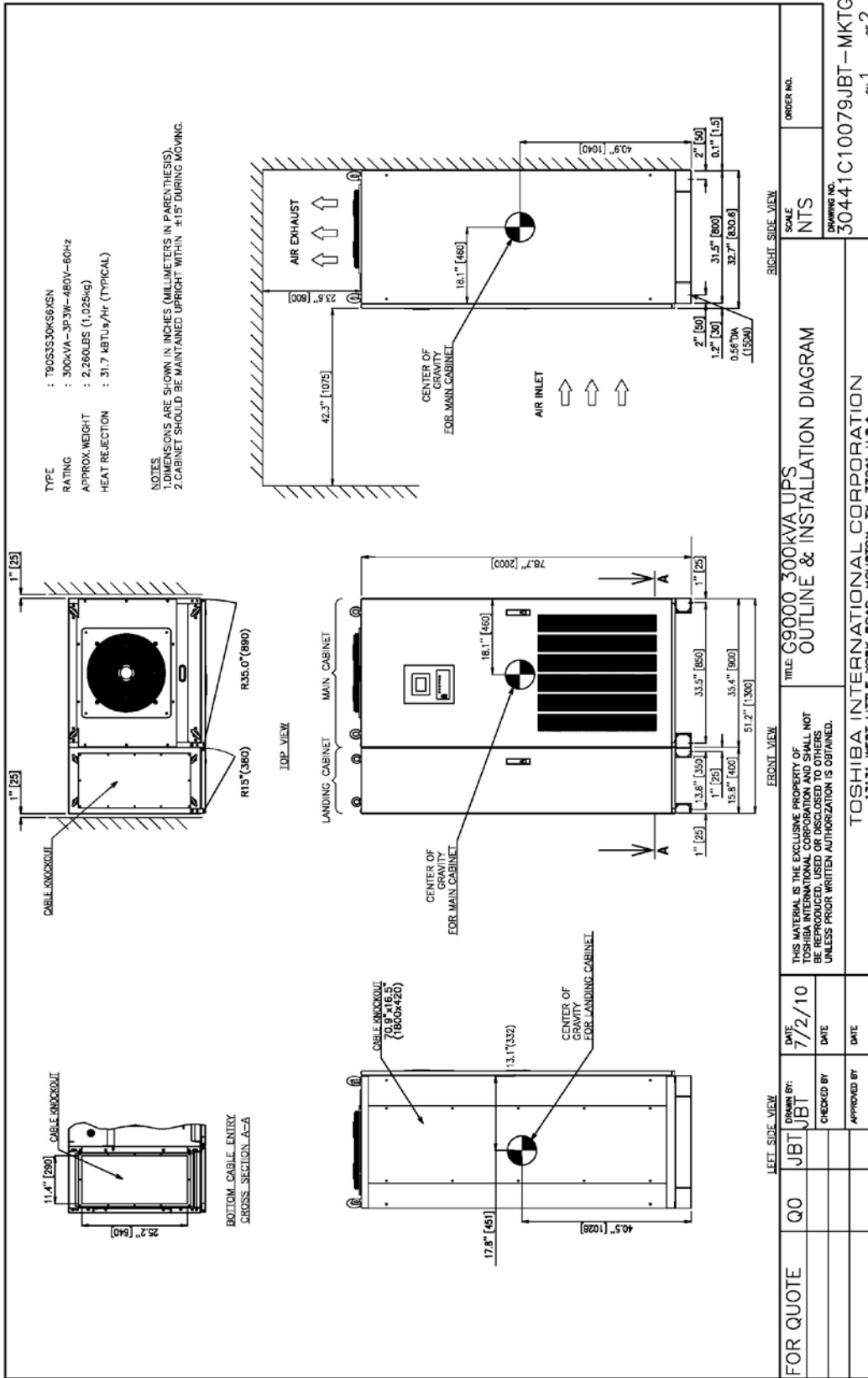

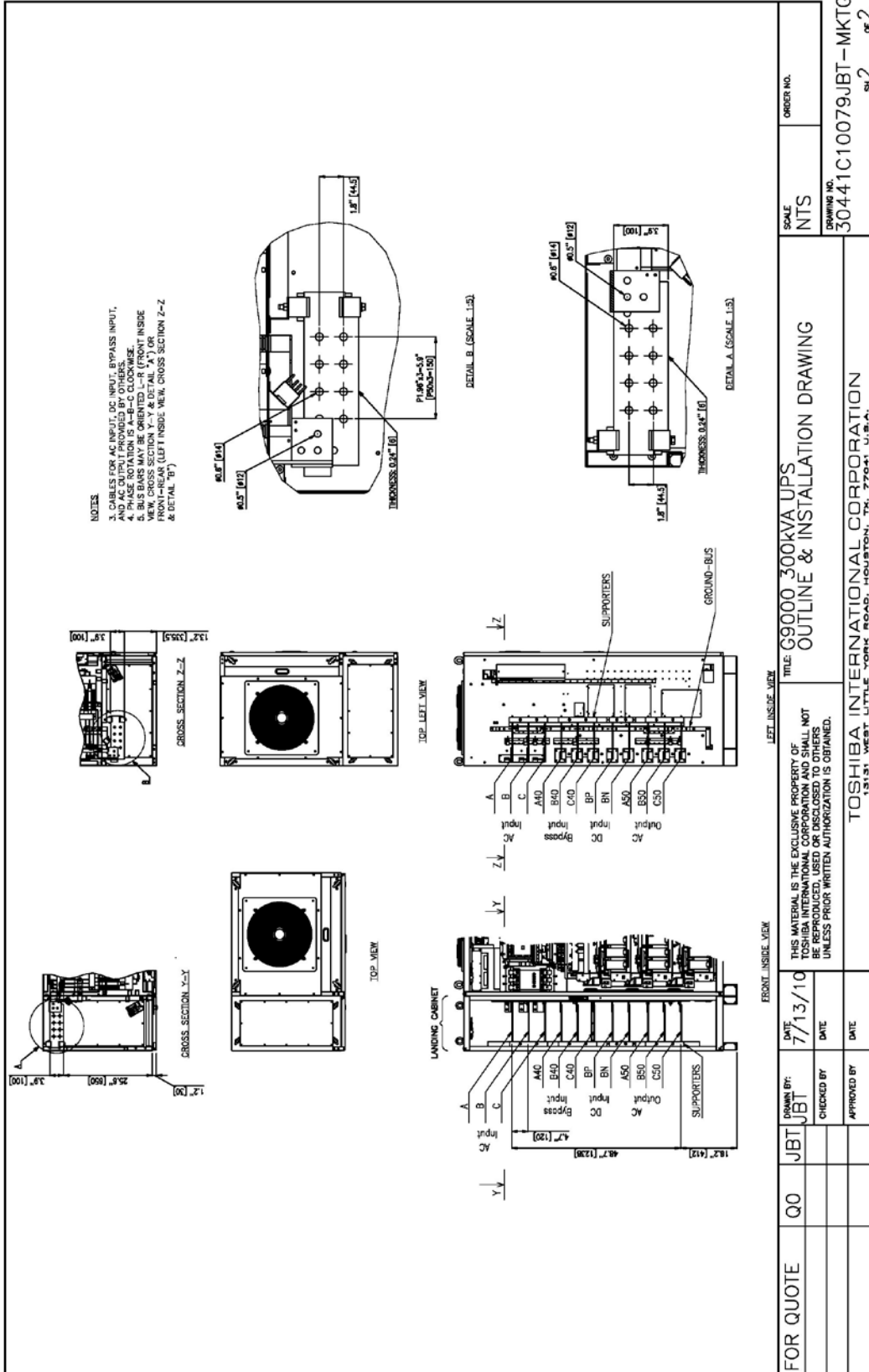

FOR QUOTE	Q0	JBT	DATE	7/13/10	TITLE: G9000 300kVA UPS OUTLINE & INSTALLATION DRAWING		SCALE	NTS	ORDER NO.
			CHECKED BY		THIS MATERIAL IS THE EXCLUSIVE PROPERTY OF TOSHIBA INTERNATIONAL CORPORATION AND SHALL NOT BE REPRODUCED, USED OR DISCLOSED TO OTHERS UNLESS PRIOR WRITER AUTHORIZATION IS OBTAINED.		DRAWING NO.	30441C10079JBT-MKTG	
			APPROVED BY		TOSHIBA INTERNATIONAL CORPORATION 13131 WEST LITTLE YORK ROAD, HOUSTON, TX 77041 U.S.A.				8x2 of 2

Installation Planning Guide for 500kVA UPS

Standard System: 480V Input, 480V Output

General Mechanical Information									
Dimensions (W x D x H)		Weight	Floor Loading	Approximate Full-Load Heat Rejection	Mechanical Clearance (Inches) from UPS for Ventilation and Maintenance Access				
Inches		Lbs.	Lbs./ft. ²	but/Hr	Top	Front	Bottom	Sides**	Back
70.9" x 32.7" x 80.7"		3360	205	52,764	23.6"	42.3"	0"	0"	0"

* Height includes removable fan housing – Frame height is 78.7".

** 0" clearance for peripheral equipment, 1" clearance for walls.

Primary AC Input (480V 3-Phase / 3-Wire)				
Maximum Input Power Demand Normal Mode (Recharge Mode)			Suggested External Overcurrent Protection	External Feeder Wire Size: Min. – Max. Per Phase
kVA	PF	Amps	Amps	AWG or kcmil at 75° C Temp. Rating
521 (560)	>0.99	626 (673)	800 AT	(3) x 300 kcmil – (3) x 350 kcmil

Alternate (Bypass) AC Input (480V 3-Phase / 3-Wire)				
Maximum Input Power Demand			Suggested External Overcurrent Protection	External Feeder Wire Size: Min. – Max. Per Phase
kVA	PF	Amps (Max.)	Amps	AWG or kcmil at 75° C Temp. Rating
500	1.0	601	800 AT	(3) x 300 kcmil – (3) x 350 kcmil

Battery Input (480VDC Nominal)			
Battery Capacity Required for Full Load Output		Suggested External Overcurrent Protection	Three (3) Cabinets: DC Cable Size per Cabinet***
kWB		Amps	AWG or kcmil at 75° C Temp. Rating
518 @ 1.0 PF		N/A – Toshiba-Supplied Battery Cabinets equipped with built-in overcurrent Protection	1 x 500 kcmil

*** Contact Toshiba Factory Representative for different multiple Battery Cabinet Configurations.

AC Output (480V 3-Phase / 3-Wire)				
Rated Output Power			Suggested External Overcurrent Protection	External Feeder Wire Size: Min. – Max. Per Phase
kVA	PF	Amps	Amps	AWG or kcmil at 75° C Temp. Rating
500	1.0	601	800 AT	(3) x 300 kcmil – (3) x 350 kcmil

Important Notes:

1. Maximum input current is limited to 106% of the full-load input current.
2. Output load conductors are to be installed in separate conduit from input conductors.
3. Control wires and power wires are to be installed in separate conduits.
4. Recommended AC input and output overcurrent protection based on continuous full load current per NEC.
5. Wiring shall comply with all applicable national and local electrical codes.
6. Grounding conductors to be sized per NEC Article 250-122. Neutral conductors to be sized per NEC Article 310.15.
 - Primary AC Input: 3 ϕ , 3-wire + ground.
 - Alternate AC Input: 3 ϕ , 3-wire + ground.
 - AC Output: 3 ϕ , 3-wire + ground.
 - DC Input: 2-wire (Positive/Negative) + ground.
7. Nominal battery voltage based on the use of VRLA type batteries (2.0 volts/cell nominal).
8. Maximum battery discharge current based on lowest permissible discharge voltage of 1.67 VPC.
9. DC wires should be sized to allow not more than a 2-volt drop at maximum discharge current.
10. Weights do not include batteries or other auxiliary equipment external to the UPS.

11. Cable sizing calculations based on the following assumptions:
 - Minimum size is smallest size based on ampacity at 30 °C.
 - Maximum size cable is based on cable bend radius limitations at the UPS terminals.
 - Not more than 3 current-carrying conductors installed in conduit in ambient temperature of 30 °C.
 - Temperature rating of copper conductors/terminals: 75 °C in conduit.
 - Reference: 2005 NEC Handbook, Table 310.16.

NOTE: Consult latest edition of applicable national and local codes for possible variations.
12. Ratings of wires and overcurrent devices are suggested minimums. Consult with a registered Professional Engineer within your local area for proper size selections.

TOSHIBA INTERNATIONAL CORPORATION
 13131 West Little York Road
 Houston, TX 77041
 Telephone: (800) 231-1412
 Fax: (713) 896-5212
 Web Site: www.toshiba.com/ind

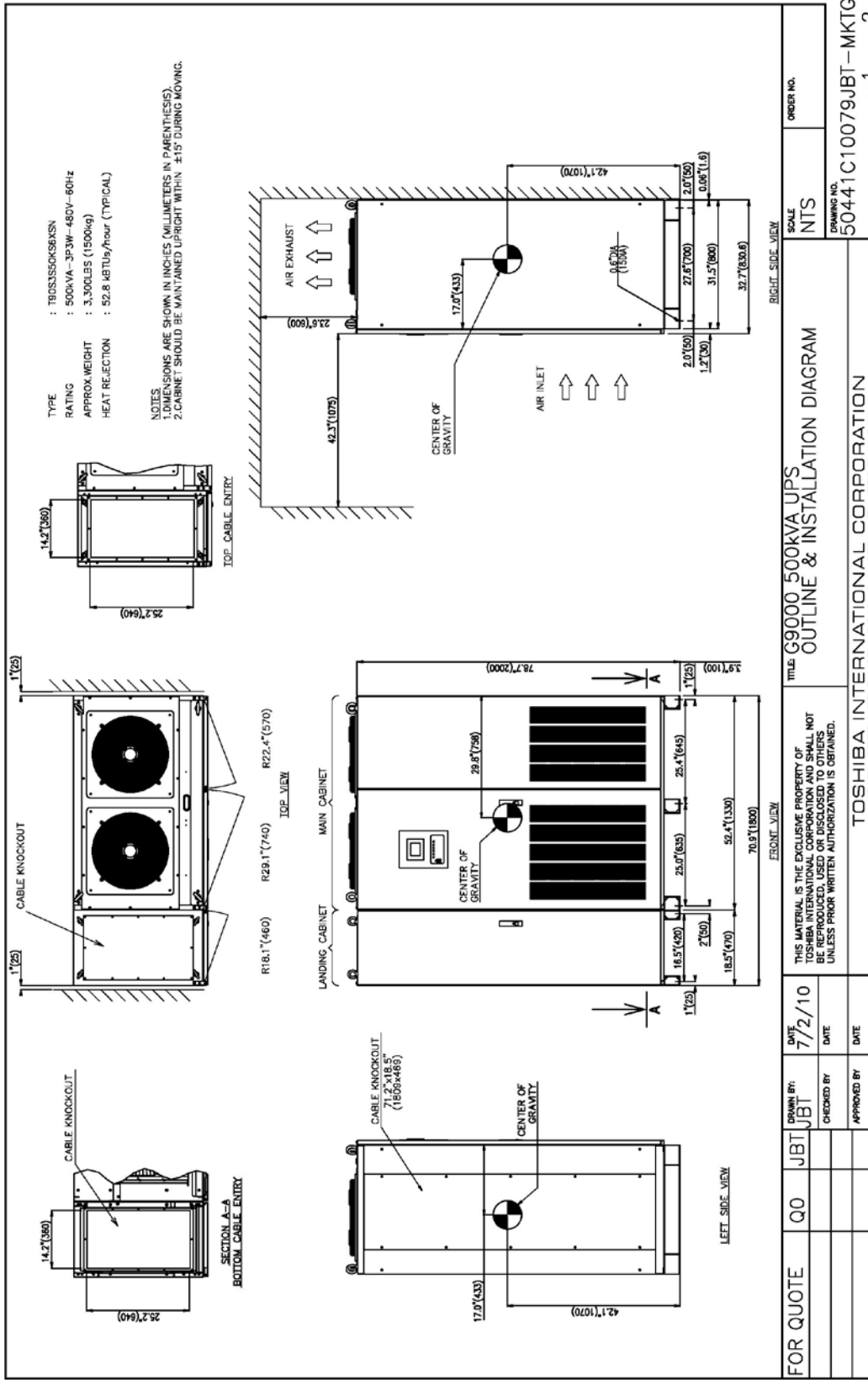

Installation Planning Guide for 650kVA UPS

Standard System: 480V Input, 480V Output

General Mechanical Information									
Dimensions (W x D x H)		Weight	Floor Loading	Approximate Full-Load Heat Rejection	Mechanical Clearance (Inches) from UPS for Ventilation and Maintenance Access				
Inches		Lbs.	Lbs./ft. ²	Btu/Hr.	Top	Front	Bottom	Sides**	Back
90.6" x 32.7" x 80.7"*		4255	207	58,594	23.6"	42.3"	0"	0"	0"

* Height includes removable fan housing – Frame height is 78.7".

** 0" clearance for peripheral equipment, 1" clearance for walls.

Primary AC Input (480V 3-Phase / 3-Wire)				
Maximum Input Power Demand Normal Mode (Recharge Mode)			Suggested External Overcurrent Protection	External Feeder Wire Size: Min. – Max. Per Phase
kVA	PF	Amps	Amps	AWG or kcmil at 75° C Temp. Rating
677 (731)	>0.99	814 (879)	1200 A	(4) x 350 kcmil - (4) x 400 kcmil

Alternate (Bypass) AC Input (480V 3-Phase / 3-Wire)				
Maximum Input Power Demand			Suggested External Overcurrent Protection	External Feeder Wire Size: Min. – Max. Per Phase
kVA	PF	Amps (Max.)	Amps	AWG or kcmil at 75° C Temp. Rating
650	1.0	782	1000 A	(3) x 400 kcmil - (4) x 250 kcmil

Battery Input (480VDC Nominal)				
Battery Capacity Required for Full Load Output		Suggested External Overcurrent Protection	Four (4) Cabinets: DC Cable Size per Cabinet***	
kWB		Amps	AWG or kcmil at 75° C Temp. Rating	
672 @ 1.0 PF		N/A – Toshiba-Supplied Battery Cabinets equipped with built-in overcurrent Protection	1 x 600 kcmil	

*** Contact Toshiba Factory Representative for different multiple Battery Cabinet Configurations.

AC Output (480V 3-Phase / 3-Wire)				
Rated Output Power			Suggested External Overcurrent Protection	External Feeder Wire Size: Min. – Max. Per Phase
kVA	PF	Amps	Amps	AWG or kcmil at 75° C Temp. Rating
650	1.0	902	1000 A	(3) x 400 kcmil - (4) x 250 kcmil

Important Notes:

1. Maximum input current is limited to 106% of the full-load input current.
2. Output load conductors are to be installed in separate conduit from input conductors.
3. Control wires and power wires are to be installed in separate conduits.
4. Recommended AC input and output overcurrent protection based on continuous full load current per NEC.
5. Wiring shall comply with all applicable national and local electrical codes.
6. Grounding conductors to be sized per NEC Article 250-122. Neutral conductors to be sized per NEC Article 310.15.
 - Primary AC Input: 3 ϕ , 3-wire + ground.
 - Alternate AC Input: 3 ϕ , 3-wire + ground.
 - AC Output: 3 ϕ , 3-wire + ground.
 - DC Input: 2-wire (Positive/Negative) + ground.
7. Nominal battery voltage based on the use of VRLA type batteries (2.0 volts/cell nominal).
8. Maximum battery discharge current based on lowest permissible discharge voltage of 1.67 VPC.
9. DC wires should be sized to allow not more than a 2-volt drop at maximum discharge current.
10. Weights do not include batteries or other auxiliary equipment external to the UPS.

11. Cable sizing calculations based on the following assumptions:
 - Minimum size is smallest size based on ampacity at 30 °C.
 - Maximum size cable is based on cable bend radius limitations at the UPS terminals.
 - Not more than 3 current-carrying conductors installed in conduit in ambient temperature of 30 °C.
 - Temperature rating of copper conductors/terminals: 75 °C in conduit.
 - Reference: 2005 NEC Handbook, Table 310.16.

NOTE: Consult latest edition of applicable national and local codes for possible variations.
12. Ratings of wires and overcurrent devices are suggested minimums. Consult with a registered Professional Engineer within your local area for proper size selections.

TOSHIBA INTERNATIONAL CORPORATION
13131 West Little York Road
Houston, TX 77041
Telephone: (800) 231-1412
Fax: (713) 896-5212
Web Site: www.toshiba.com/ind

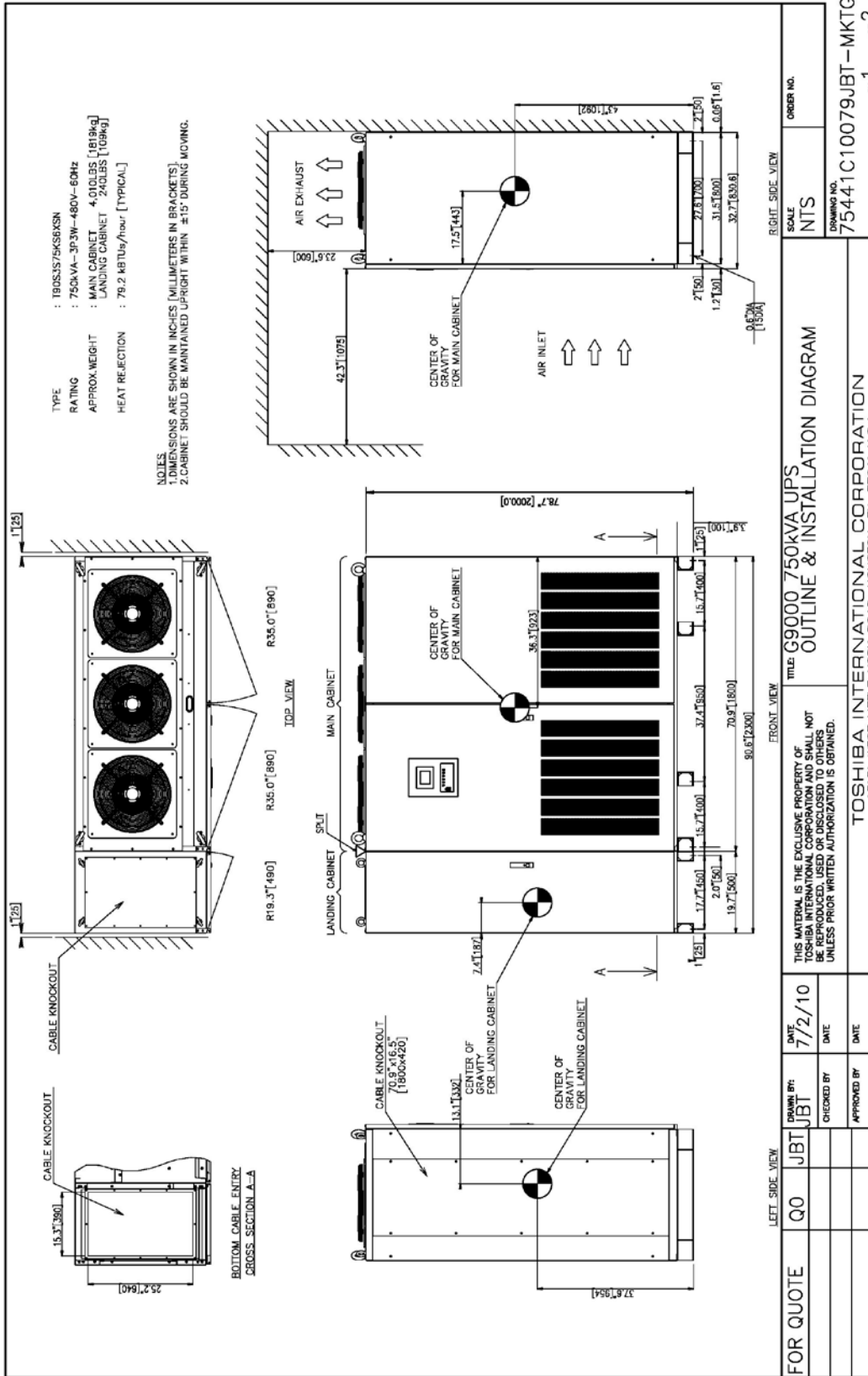

NOTE: Physical layout and dimensions of 650kVA and 750kVA models are identical

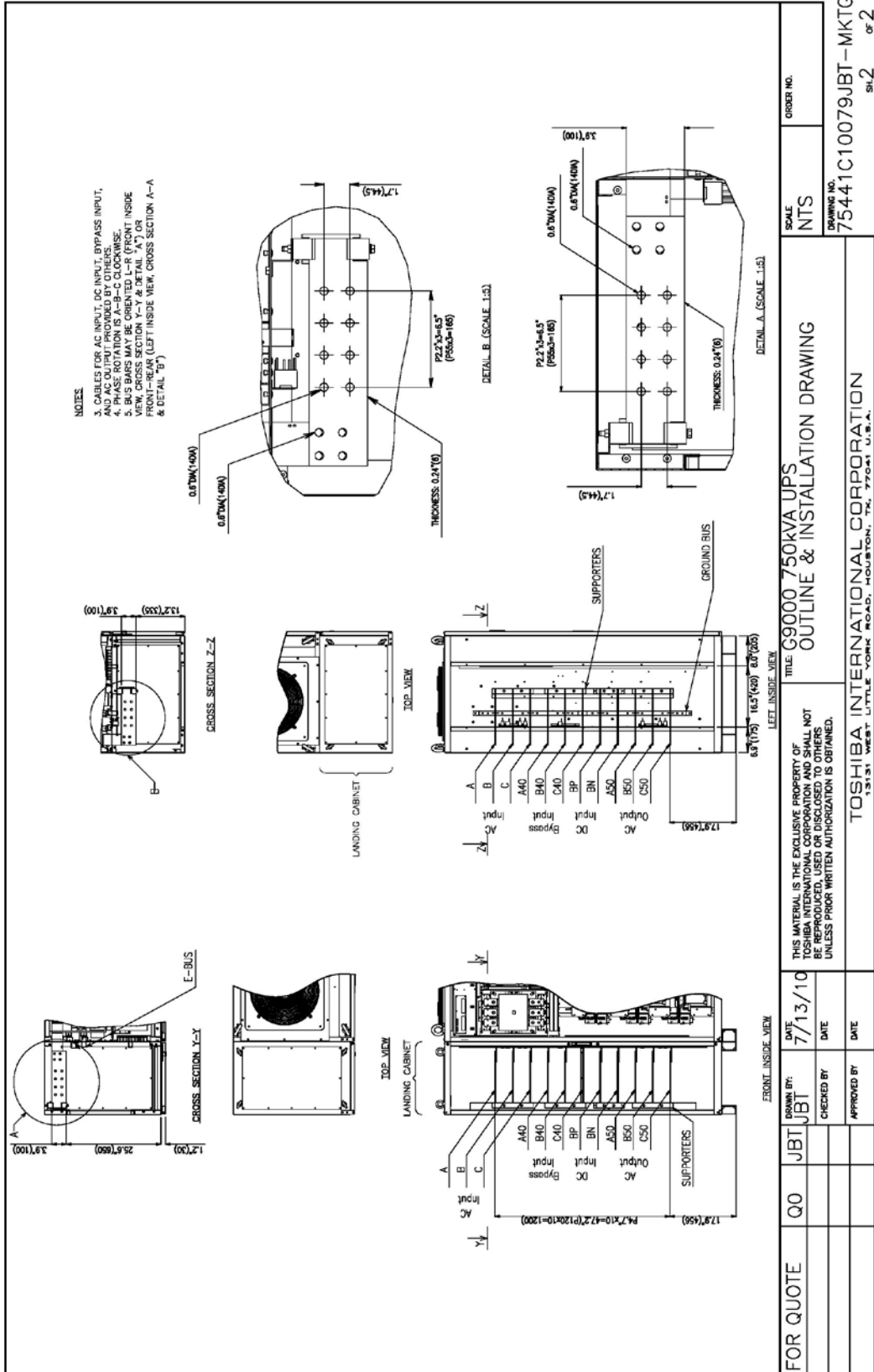

FOR QUOTE	Q0	JBT	DATE: 7/13/10	DATE: 7/13/10	DATE: 7/13/10
			DOWN BY: JBT	CHECKED BY:	APPROVED BY:
TITLE: G9000 750kVA UPS OUTLINE & INSTALLATION DRAWING			SCALE: NTS	ORDER NO.	
TOSHIBA INTERNATIONAL CORPORATION 13131 WEST LITTLE YORK ROAD, HOUSTON, TX 77041 U.S.A.			DRAWING NO. 75441C10079JBT-MKTG		SH.2 of 2

NOTE: Physical layout and dimensions of 650kVA and 750kVA models are identical

Installation Planning Guide for 750kVA UPS

Standard System: 480V Input, 480V Output

General Mechanical Information								
Dimensions (W x D x H)	Weight	Floor Loading	Approximate Full-Load Heat Rejection	Mechanical Clearance (Inches) from UPS for Ventilation and Maintenance Access				
Inches	Lbs.	Lbs./ft. ²	Btu/Hr.	Top	Front	Bottom	Sides**	Back
90.6" x 32.7" x 80.7"*	4255	207	79,147	23.6"	42.3"	0"	0"	0"

* Height includes removable fan housing – Frame height is 78.7".

** 0" clearance for peripheral equipment, 1" clearance for walls.

Primary AC Input (480V 3-Phase / 3-Wire)				
Maximum Input Power Demand Normal Mode (Recharge Mode)			Suggested External Overcurrent Protection	External Feeder Wire Size: Min. – Max. Per Phase
kVA	PF	Amps	Amps	AWG or kcmil at 75° C Temp. Rating
781 (840)	>0.99	939 (1010)	1200 A	(4) x 350 kcmil - (5) x 250 kcmil

Alternate (Bypass) AC Input (480V 3-Phase / 3-Wire)				
Maximum Input Power Demand			Suggested External Overcurrent Protection	External Feeder Wire Size: Min. – Max. Per Phase
kVA	PF	Amps (Max.)	Amps	AWG or kcmil at 75° C Temp. Rating
750	1.0	902	1200 A	(4) x 350 kcmil - (5) x 250 kcmil

Battery Input (480VDC Nominal)				
Battery Capacity Required for Full Load Output		Suggested External Overcurrent Protection		Four (4) Cabinets: DC Cable Size per Cabinet***
kWB		Amps		AWG or kcmil at 75° C Temp. Rating
776 @ 1.0 PF		N/A – Toshiba-Supplied Battery Cabinets equipped with built-in overcurrent Protection		1 x 750 kcmil

*** Contact Toshiba Factory Representative for different multiple Battery Cabinet Configurations.

AC Output (480V 3-Phase / 3-Wire)				
Rated Output Power			Suggested External Overcurrent Protection	External Feeder Wire Size: Min. – Max. Per Phase
kVA	PF	Amps	Amps	AWG or kcmil at 75° C Temp. Rating
750	1.0	902	1200 A	(4) x 350 kcmil - (5) x 250 kcmil

Important Notes:

13. Maximum input current is limited to 106% of the full-load input current.
14. Output load conductors are to be installed in separate conduit from input conductors.
15. Control wires and power wires are to be installed in separate conduits.
16. Recommended AC input and output overcurrent protection based on continuous full load current per NEC.
17. Wiring shall comply with all applicable national and local electrical codes.
18. Grounding conductors to be sized per NEC Article 250-122. Neutral conductors to be sized per NEC Article 310.15.
 - Primary AC Input: 3 ϕ , 3-wire + ground.
 - Alternate AC Input: 3 ϕ , 3-wire + ground.
 - AC Output: 3 ϕ , 3-wire + ground.
 - DC Input: 2-wire (Positive/Negative) + ground.
19. Nominal battery voltage based on the use of VRLA type batteries (2.0 volts/cell nominal).
20. Maximum battery discharge current based on lowest permissible discharge voltage of 1.67 VPC.
21. DC wires should be sized to allow not more than a 2-volt drop at maximum discharge current.
22. Weights do not include batteries or other auxiliary equipment external to the UPS.

23. Cable sizing calculations based on the following assumptions:
 - Minimum size is smallest size based on ampacity at 30 °C.
 - Maximum size cable is based on cable bend radius limitations at the UPS terminals.
 - Not more than 3 current-carrying conductors installed in conduit in ambient temperature of 30 °C.
 - Temperature rating of copper conductors/terminals: 75 °C in conduit.
 - Reference: 2005 NEC Handbook, Table 310.16.

NOTE: Consult latest edition of applicable national and local codes for possible variations.
24. Ratings of wires and overcurrent devices are suggested minimums. Consult with a registered Professional Engineer within your local area for proper size selections.

TOSHIBA INTERNATIONAL CORPORATION
 13131 West Little York Road
 Houston, TX 77041
 Telephone: (800) 231-1412
 Fax: (713) 896-5212
 Web Site: www.toshiba.com/ind

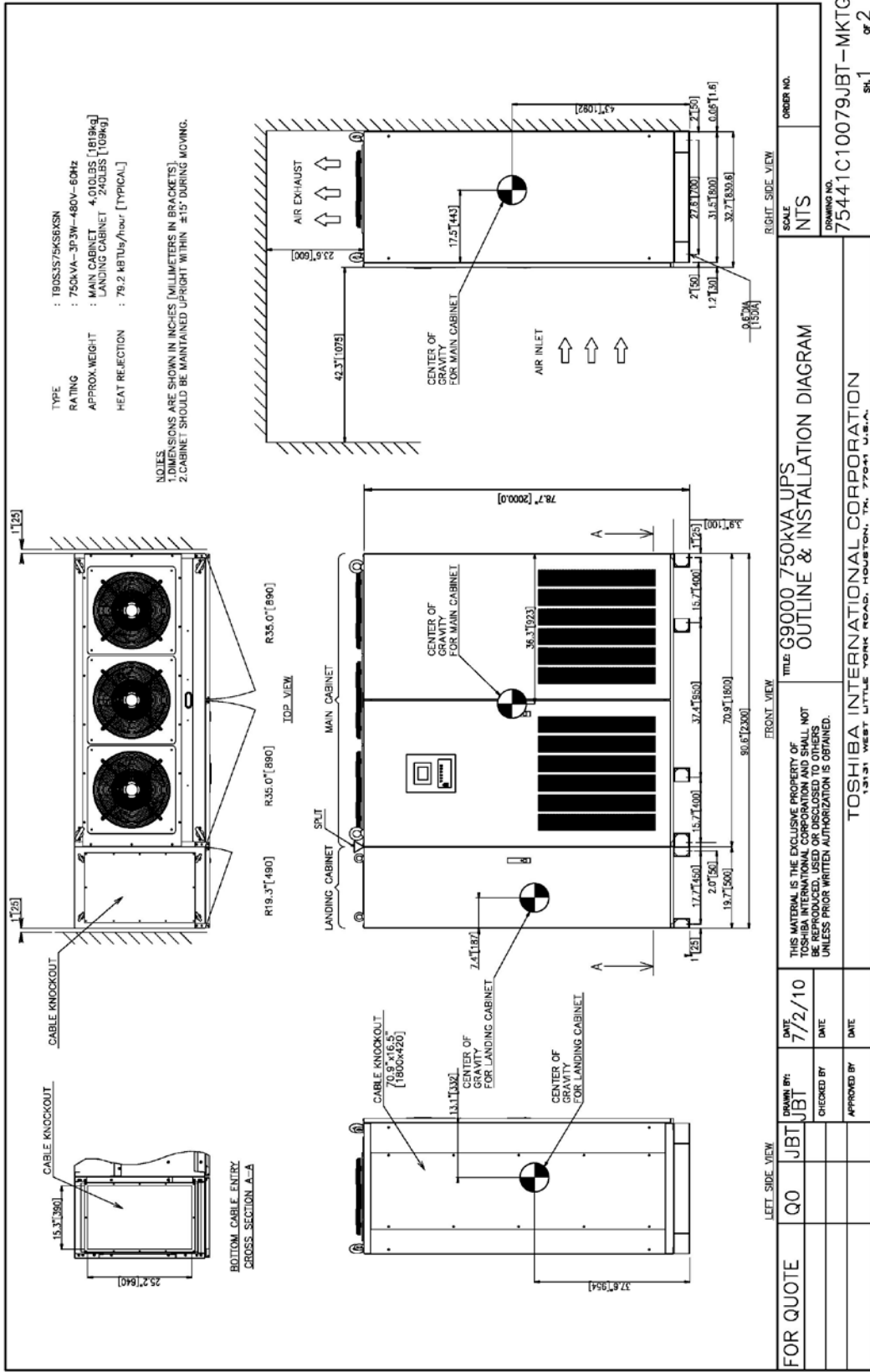

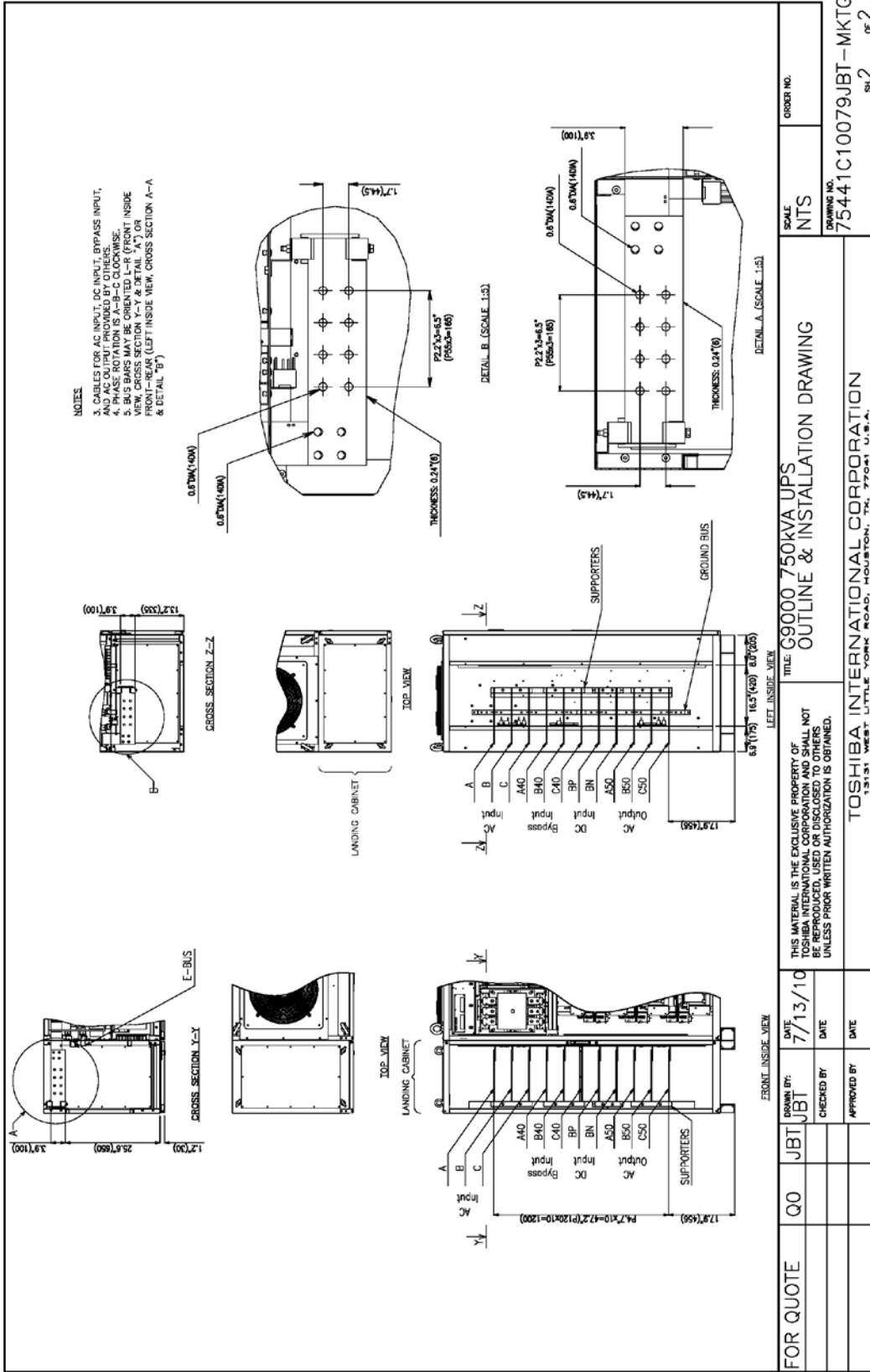

TOSHIBA

TOSHIBA INTERNATIONAL CORPORATION
SOCIAL INFRASTRUCTURE SYSTEMS GROUP
POWER ELECTRONICS DIVISION

13131 West Little York Rd., Houston, TX 77041

Tel: 713/466-0277 Fax 713/466-8773

US 877/867-8773 Canada 800/872-2192 Mexico 01/800/527-1204

www.toshiba.com/tic/industrial/uninterruptible-power-systems

Printed in Japan