

TOP VIEW

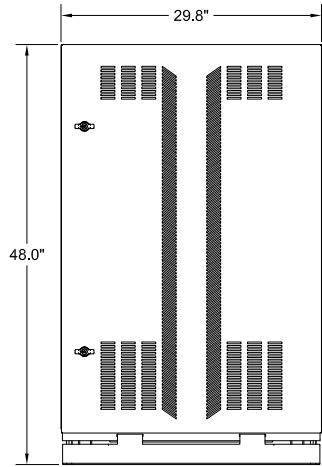

FRONT VIEW

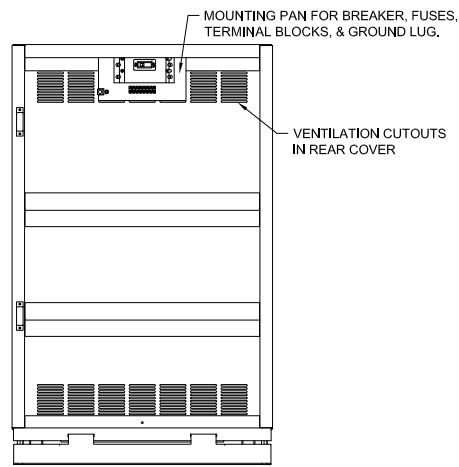

FRONT VIEW (DOOR REMOVED)

RIGHT SIDE VIEW

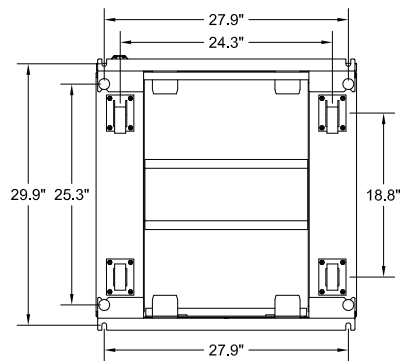
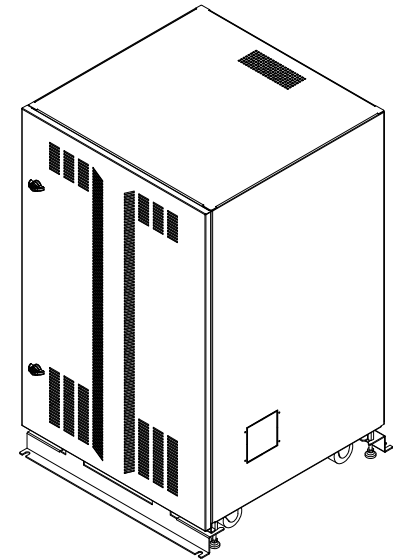
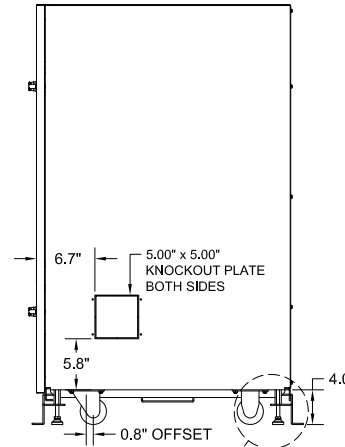

BOTTOM VIEW

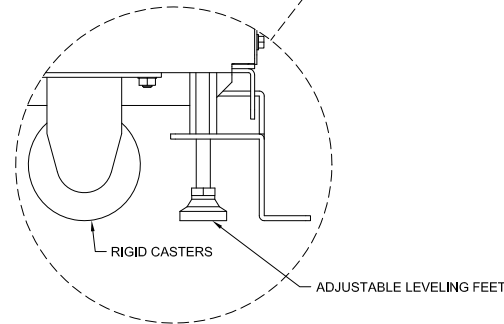

DETAIL VIEW

**CABINET NOTES:**

1. NEMA 1 ENCLOSED BATTERY CABINET.
2. FACTORY ASSEMBLED CABINETS ARE LISTED TO UL 1778.
3. WELDED STEEL CONSTRUCTION.
4. INTERIOR & EXTERIOR FINISH IS BLACK SAND TEXTURE POWDER COAT, OVEN BAKED FOR CHIP & CORROSION RESISTANT FINISH.
5. FOR EASE OF CONDUIT INSTALLATION, (1) 5" X 5" CONDUIT PLATE IS PROVIDED TO REPLACE A KNOCKOUT IN THE CABINET.
6. BATTERIES CAN BE ACCESSED FROM THE FRONT & REAR OF THE CABINET.
7. CABINET IS SUPPLIED ON SKID WITH HEAVY DUTY RAMP FOR EASY UNLOADING. CABINET IS TO BE MOVED USING THE CABINET CASTERS.

<b>BC20 BATTERY CABINET</b>			
FOR USE W/ POWERSHIELD 3200 SERIES 10-20 KVA UPS			
<b>MECHANICAL DRAWING</b>			
DIMENSIONS ARE IN INCHES		INITIALS	DATE
TOLERANCES:		DRAWN	JRL 08/22/11
DECIMALS: .XX ±.13	ANGLES: ±1°	CHECKED	CH 08/22/11
MATERIAL: SEE NOTES SHEET 1		THE INFORMATION CONTAINED IN THIS DRAWING IS THE SOLE PROPERTY OF C&C POWER, INC. ANY REPRODUCTION WITHOUT THE WRITTEN CONSENT OF C&C POWER, INC IS PROHIBITED.	
FINISH: SEE NOTES SHEET 1		<b>C&amp;C POWER</b> ENGINEERED POWER PRODUCTS 949 N. Larch Ave. - Elmhurst, IL 60126	
CAD GENERATED DRAWING DO NOT MANUALLY UPDATE			
SCALE: SEE NOTES SHEET 1	REV: 1	© 2011 C&C POWER, INC. ALL RIGHTS RESERVED	
SHEET 1 OF 2			

DRAWING # 91429-SDC01-2 REV 1

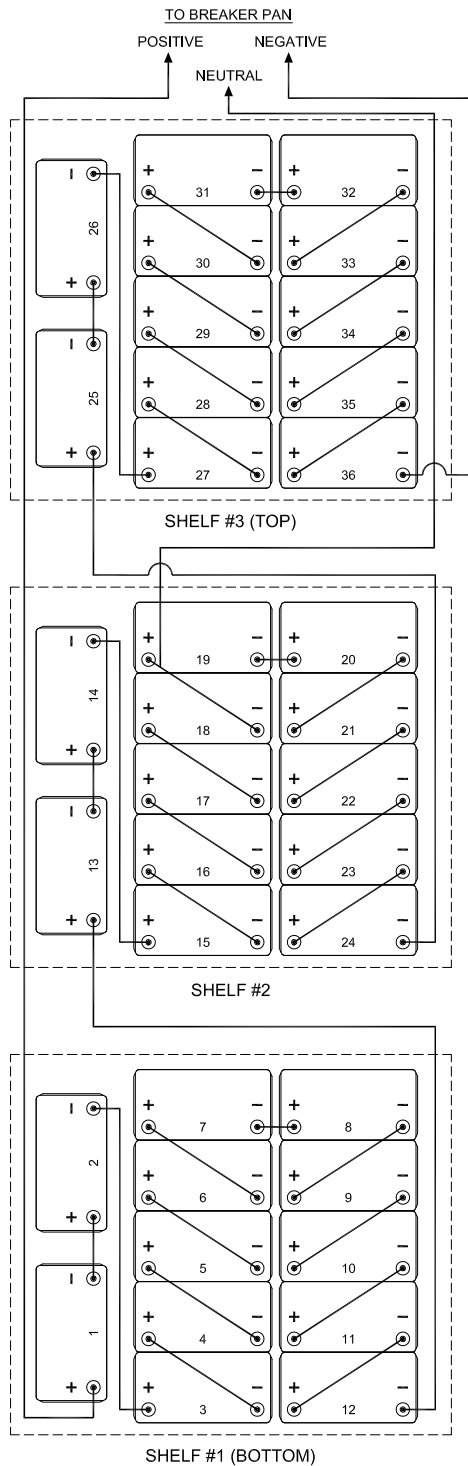

432VDC (+216/-216) TYPICAL WIRING

**BREAKER PAN**

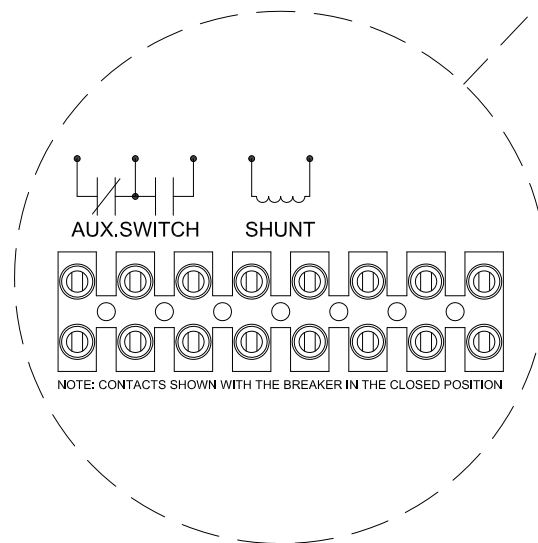
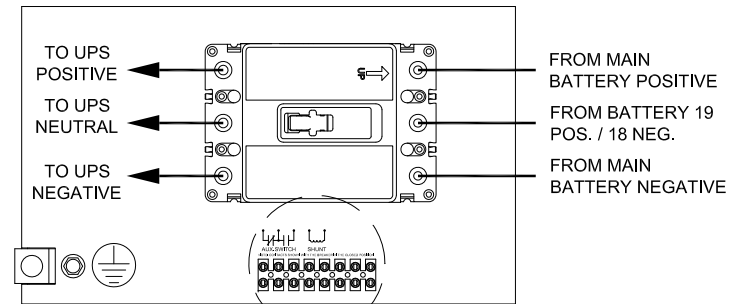

**ELECTRICAL NOTES:**

1. ALL INTERNAL WIRING IS UL LISTED, MTW, STYLE, 105C, EXTRA FLEXIBLE CABLE.
2. BREAKER IS UL LISTED.
3. BATTERY CABINETS WITH BREAKERS ARE SHIPPED WITH BREAKER IN THE OFF/OPEN POSITION.
4. CABLES FROM BATTERY CABINET TO UPS SYSTEM ARE SUPPLIED BY OTHERS.
5. GROUND CONNECTION IS #6-300MCM MECHANICAL LUG.

<b>BC20 BATTERY CABINET</b>			
FOR USE W/ POWERVAR 3200 SERIES 10-20 KVA UPS			
<b>ELECTRICAL DRAWING</b>			
DIMENSIONS ARE IN INCHES	INITIALS	DATE	THE INFORMATION CONTAINED IN THIS DRAWING IS THE SOLE PROPERTY OF C&C POWER, INC. ANY REPRODUCTION WITHOUT THE WRITTEN CONSENT OF C&C POWER, INC IS PROHIBITED.
TOLERANCES:	DRAWN	08/22/11	
DECIMALS: .XX ±.03 .XXX ±.015	JRL	08/22/11	
MATERIAL: SEE NOTES SHEET 1		CHECKED	CH 08/22/11
FINISH: SEE NOTES SHEET 1		<b>C&amp;C POWER</b>	
CAD GENERATED DRAWING DO NOT MANUALLY UPDATE		<b>ENGINEERED POWER PRODUCTS</b>	
SCALE: SEE NOTES SHEET 1	REV: 1	949 N. Larch Ave. - Elmhurst, IL 60126	
SHEET 2 OF 2		© 2011 C&C POWER, INC. ALL RIGHTS RESERVED	